

# EcoStruxure Modular Data Center – Dual Bay 45’

180 KW / 50Hz All in One Datacenter Module

## Technical Specification

Version 3.1



**Project name:** EDGE BASE DESIGN  
**Customer** 0  
**Date** 22/04/2021

**BFO #** PFMIET180D1R028B  
**Revision** 1



# Table of Contents

1	Introduction.....	4
1.1	Context .....	4
1.2	Main benefits .....	4
1.3	Scope of work.....	4
2	Prefabricated Datacenter.....	5
2.1	Introduction .....	5
2.2	Concept and Dimensions for Prefabricated Module.....	5
2.2.1	Prefabricated Solution for 28 Racks.....	5
2.3	Structural design.....	6
2.3.1	Steel Frame Design.....	6
2.3.2	Wall design .....	6
2.3.3	Floor .....	7
2.3.4	Doors .....	7
2.3.5	Cable Glands.....	8
2.3.6	Air Renovation System (optional).....	9
2.4	Technical Specifications .....	9
2.4.1	Shock-load.....	9
2.4.2	Wind load.....	9
2.4.3	Roof load .....	9
2.4.4	Floor load.....	9
2.4.5	External temperature range.....	10
2.4.6	Internal environmental conditions.....	10
2.4.7	Fire resistance .....	10
2.4.8	Painting.....	10
2.5	Mounting Pad support.....	10
2.6	Lifting elements.....	10
2.7	Standards .....	11
3	Electrical System .....	13
3.1	Conceptual Single Line Diagram .....	13
3.2	Components .....	13
3.3	Room Power Distribution .....	14
3.3.1	Benefits.....	14
3.4	Grounding.....	15
4	Monitoring System.....	16
4.1	EcoStruxure IT Expert .....	16
4.2	Environmental Monitoring.....	17
5	Fire Suppression System.....	19
5.1	Fire Control Panel.....	19
5.2	Smoke Detector .....	20

5.3	Extinguishing system .....	20
5.3.1	NOVEC 1230.....	20
6	Cooling .....	22
7	GALAXY VM - Uninterruptible Power Supply (UPS)...	25
8	Racks - NetShelter SX/SV .....	30
8.1	Rack Power Distribution .....	33
9	Exclusions .....	36

# 1 Introduction

## 1.1 Context

The purpose of the document is to introduce and present the technical specification of the EcoStruxure Modular Data Center 179,2 kW All in One Datacenter Module offered by Schneider Electric.

EcoStruxure Modular Data Center solution provides a fully functional Data Center inside a prefabricated module, with complete infrastructure including: cooling, power, structural protection, fire protection, monitoring, access control, etc., within a secure environment design, comprising a modular and flexible approach, in a generous space.

This solution consists of a constructive solution of equivalent quality to a proper room dedicated to IT, including the entire necessary infrastructure.

The environment has been designed to provide the following qualities:

- Usability for IT and technical operations
- Security: Mechanical, Electrical, Cooling
- High quality, robust structure
- Reduced time to acquire and deploy

## 1.2 Main benefits

Prefabricated Datacenter Modules are the latest trend in the datacenter industry intended to decrease the time to acquire and deploy new datacenter capacity, improve the predictability and reliability of a new datacenter build and reduce upfront and ongoing capital expenditures.

All equipment in the proposed module are pre-installed and tested in our factories, reducing on-site construction risks and reducing time allocated for site works and commissioning.

Schneider Electric is a worldwide market leader in the data center business worldwide with complete integrated solutions including prefabricated modules, UPS, power distribution, cooling, software, monitoring, and enclosures. Our installed base gives us a thorough knowledge of data center market evolution, future needs and an understanding of business challenges.

## 1.3 Scope of work

### **This proposal covers a complete prefabricated module**

This document mainly covers the following topics:

- Enclosure structure and design
- UPS
- Electrical distribution
- Cooling
- IT Infrastructure (Racks, rack and row level power distribution)
- Fire suppression and detection
- Monitoring

## 2 Prefabricated Datacenter

### 2.1 Introduction

The following proposal is for an All in One prefabricated Module that is a separate prefabricated structure. This module provides the complete functionality for a 179,2 KW Datacenter environment providing power, cooling, and access for an IT environment.

### 2.2 Concept and Dimensions for Prefabricated Module

#### 2.2.1 Prefabricated Solution for 28 Racks



Solution for 28 racks includes:

- 2 x 45' Module: 45' (13.72m) x 21' (6.4m) x 11.8' (3.6m) (LxWxH)
- Uninterruptible Power Supply – GALAXY VM 200KVA
- Busbar Canalis distributing power to each IT rack.
  - Input Voltage 400 VAC, Output Voltage 400 VAC
- Electrical configuration
  - General power, lights and HVAC on non-critical power
  - IT racks on UPS power (UPS GALAXY VM 200KVA)
- Cooling
  - (12) ACRD301S, N+1 configuration
  - See cooling description for external condensers rated temperature ambient
  - Humidifier with controller - Not included
- Racks – NetShelter SX Enclosures
  - (28) [[Value not found]] - [[Value not found]] (WxDxH),
- METERED Rack PDU – (56) AP8853 - Rack PDU 2G, Metered, ZeroU, 32A, 230V, (36) C13 & (6) C19
- Netbotz 750 environmental monitoring system monitoring the following
  - Internal temperature
  - Internal humidity

- Leak detection
  - External Door Status
  - Security camera monitoring
- Automatic fire extinguishing system
  - Cable glands for power, refrigerant piping, and fiber entrance into the module

**Options:**

- Automatic transfer switch included for generator input as optional

## 2.3 Structural design

The SmartShelter Dual Bay Structural framework will be made of steel with a fully welded design frame to support the installed equipment. The walls and the roof will be constructed from modular insulated panels fit to size for the module. The total solution will be constructed from (2) individual modules assembled together on site.

The special features of the insulated panels provide the right Data Center environment.

### 2.3.1 Steel Frame Design

The frame consists of fully welded structural steel members with a base box frame with cross member for additional stiffness. Vertical pillars on the corners will support 2 main longitudinal truss beams. The truss beams provide additional structural stiffness, support a majority of the internal ceiling mounted infrastructure, and create an angled roof system that facilitates drainage.

Base-Skid assembly constructed of S275JR steel in hot rolled, plates and I-Beam profiles for support of structure for walls and ceilings. Underside of base is insulated with a polyurethane layer of  $\geq 30\text{mm}$ .

External dimensions <sup>(1)</sup>	Imperial	Metric
Length	45'	13.716 mm
Width	126.0"	6.400 mm
Height	142.9"	3.630 mm

<sup>(1)</sup> 2% tolerance

### 2.3.2 Wall design

EcoStruxure Modular Data Center offers high levels of thermal and fire protection. Rockwool panels close the area inside the module providing a clean area proper for a DC.

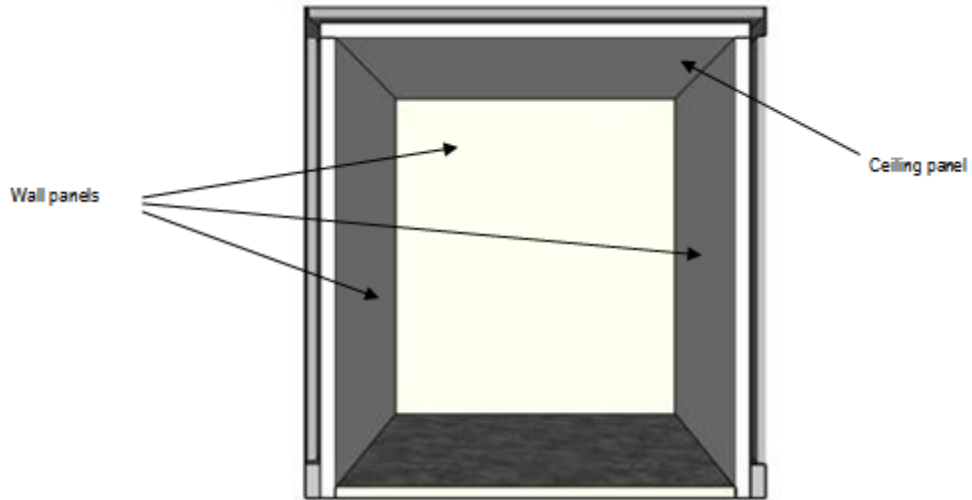

Panels are installed on the walls and ceiling and are composed by a sandwich of materials with fire resistance and thermal insulating, to resist high temperatures and provide a watertight enclosure. The sandwich is covered by one layer of galvanized steel sheet (0,6 mm), joined by continuous weld panel to panel.

**Main features:**

- Wall construction involves complete covering of the wall and roof support structure to eliminate any thermal bridge
- Thickness: 80 mm = 3.1"
- Thermal resistance, K1 (panel): 0,470 W/m2K
- Fire resistance: EI60, per EN 13501-2
- Certification IPX5 per EN 60529

<b>Final Inner dimensions</b> <sup>(1)</sup>	Imperial	Metric
Length	533"	13.556 mm
Width	246"	6.240 mm
Height	118"	3.000 mm

<sup>(1)</sup> 2% tolerance

**2.3.3 Floor**

EcoStruxure Modular Data Center base frame is covered with a 6mm steel plate floor to allow equipment to be mechanically fixed with screws and support profiles. Steel frame floor is covered with aluminum diamond plate for final finishing.

**2.3.4 Doors**

The EcoStruxure Modular Data Center includes two EI90 standard door. This door fulfills all regular requirements and requirements as an emergency exit. It is made of steel and is painted and protected against rust.

Doors are RC2 break-in resistance level in accordance with EN 1627/1630.

All Doors supplied with:

LEAF	
Steel plate finishes	1,2 mm
High-density fiberboard for fire protection with EI 90	60 mm
<b>Total thickness</b>	<b>63 mm</b>
FRAMEWORK	
Steel profile	1,5 mm
Intumescent seal	1,9 mm
FITTINGS & MECHANISMS	
Steel bearing hinges	3 u
PVC & steel handle with lock door	
Electric strike	
Quick push panic bar	
Self-closing system	

**Dimensions:**

	Width		Height
	Simple door	Double door	
<b>External dimensions</b>	1.280 mm 50,4"	1.740 mm 68,5"	2.380 mm 93,7"
<b>Internal dimensions</b>	1.100 mm 43,3"	1.600 mm 63"	2.200 mm 86,6"

**2.3.5 Cable Glands**

Roxtec cable glands will be installed at all cabling and piping interface points that enter or exit the module. Cable glands provide thermal, fire, and water protection for the module. The cable gland is easily configurable to adapt to the number and dimensions of cables and pipes that enter the module since it uses a compression unit inside of frame.

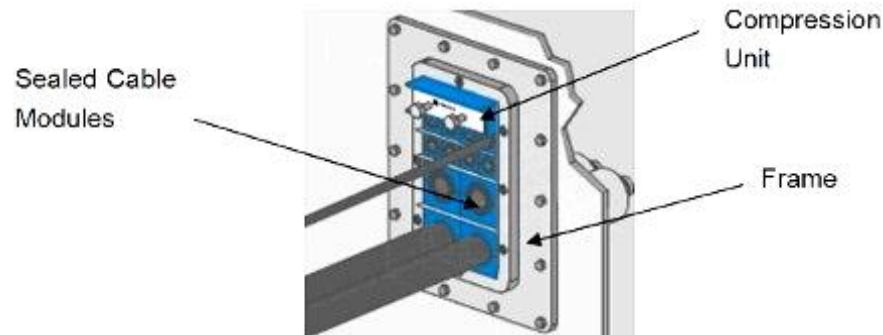



### 2.3.6 Air Renovation System (optional)

The Air Renovation System (ARS) is a ventilation unit designed to meet air renovation requirements to comply with local regulations in Prefabricated Data Centers where IT equipment and UPS batteries are installed.

To provide the proper airflow, an EC fan intakes outside air via a grille attached to G4 and G7 filters. In accordance with ASHRAE, IT spaces require air filtering (minimum F7 / MERV13).

UNIT COMPONENTS	ARS (CE)
EC Radial fan	✓
Air filter G4 efficiency (MERV 8)	✓
Air filter F7 efficiency (MERV 13)	✓
Air filter F9 efficiency (MERV 16) <sup>(1)</sup>	optional
Sand trap	optional
Electrical heater (antifreeze)	optional
Timer	optional
Door switch	optional
VOC control (Volatile organic compound)	optional
H <sub>2</sub> control sensor	optional
Combined H <sub>2</sub> + VOC sensor	optional
Change power supply	under request

✓ Standard component

× Not available

(1): Other filters under request

## 2.4 Technical Specifications

The module is designed to provide a controlled environment suitable for equipment and personnel. The units will be capable for delivery and installation on site without any permanent deformation or failure.

### 2.4.1 Shock-load

Building module units can withstand normal transportation conditions before installation on the site, without deformation or damage. Shock of 2g, 10 millisecond duration for transport conditions per IEC 60068-2-64.

### 2.4.2 Wind load

The module can withstand non-sustained wind speeds up to 160km/h per Eurocode EN1991-1-4, applied to the walls of the enclosure.

### 2.4.3 Roof load

The module can withstand snow load of 245 kg/m<sup>2</sup> on roof (14,600 kg total)

### 2.4.4 Floor load

The module can withstand floor loads up to 1.000kg/m<sup>2</sup> across the entire floor structure. Specific bracing for heavy components such as battery cabinets is provided.

### 2.4.5 External temperature range

See below cooling technical specifications

### 2.4.6 Internal environmental conditions

The internal conditions will maintain ASHRAE TC 9.9 recommended temperature and humidity ranges.

### 2.4.7 Fire resistance

1 hour fire resistant construction for enclosure walls, roof, and doors is provided.

### 2.4.8 Painting

EcoStruxure Modular Data Center have two primer epoxy and two final polyurethane coats in a RAL 9003 standard color. This surface treatment provides C3 corrosion protection with medium durability (5 to 15 years).

Per ISO 12944 standard, a C3 protection works well in exterior environments with average sulfide oxide (IV) contamination level, inshore areas of low salinity and interior environment with high humidity and certain air contamination.

## 2.5 Mounting Pad support

The module must be placed on a foundation with continuous support for the perimeter walls. The foundation must be level and engineered to support the final total load of the installed and operational module.

## 2.6 Lifting elements

The module frame has been analyzed for lifting, transport and on-site conditions at its maximum dimensions under a total load of 51,900 kg, including frame and wall panel weight.

Each EcoStruxure Modular Data Center is equipped with top lifting points, at each corner, for primary lifting by a crane. The EcoStruxure Modular Data Center must be lifted using standard load spreading techniques in a manner to ensure each will remain



**Figure 1a- Lifting Data  
Hall section with spreader  
bars: two crane option**

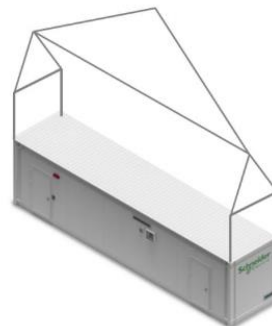

**Figure 1b- Lifting Data  
Hall section with spreader  
bars: one crane option**

horizontal and balanced throughout the move using the lifting attachment points provided.

All lifting equipment must have the necessary capacity to withstand specified loads [including Factors of Safety]. It should be noted that the center of gravity of each of the EcoStruxure Modular Data Center do not align with the geometric center. One option is to use an “H” style Adjustable Lift Beam. Horizontality must be verified on site and the central lifting cable must be adjusted (in both perpendicular directions) before starting the lifting operation to ensure that no tilting or swinging occurs.

## 2.7 Standards

### Metallic Frame

- EN 1990 Eurocode - Basis of structural design
- EN 1090-2 Execution of steel structures - Part 2: Technical requirements for steel structures
- EN 1991 Eurocode 1 - Actions on structures
- EN 1993 Eurocode 3 - Design of steel structures
- EN 10025 Hot rolled products of structural steels
- ISO 15607 Specification and qualification of welding procedures for metallic materials - general rules
- ISO 15609 Specification and qualification of welding procedures for metallic materials — Welding procedure specification
- EN 9606 Qualification testing of welders

### Surface treatment

- ISO 12944 Corrosion protection of steel structures by protective paint systems
- ISO 9223 Corrosive atmospheres

### Insulation Walls

- EN 13501 Fire classification of construction products and building elements.
- EN 1364 Fire resistance tests for non-loadbearing elements. Walls
- EN 10169 Continuously organic coated (coil coated) steel flat products.
- EN 14509 QC. Self-supporting double skin metal faced insulating panels. Factory made products. Specifications
- EN 10346 Structural adhesives. Determination of the pot life (working life) of multi-component adhesives
- EN 13162 Thermal insulation products for buildings. Factory made mineral wool (MW) products.

### Doors

- EN 13501 Fire classification of construction products and building elements.

- EN 12425 Industrial, commercial and garage doors and gates. Resistance to water penetration. Classification.
- EN 12489 Industrial, commercial and garage doors and gates. Resistance to water penetration. Test method.
- EN 1191 Windows and doors. Resistance to repeated opening and closing.

### 3 Electrical System

Following is the description of the electrical system provided inside the module.

#### 3.1 Conceptual Single Line Diagram

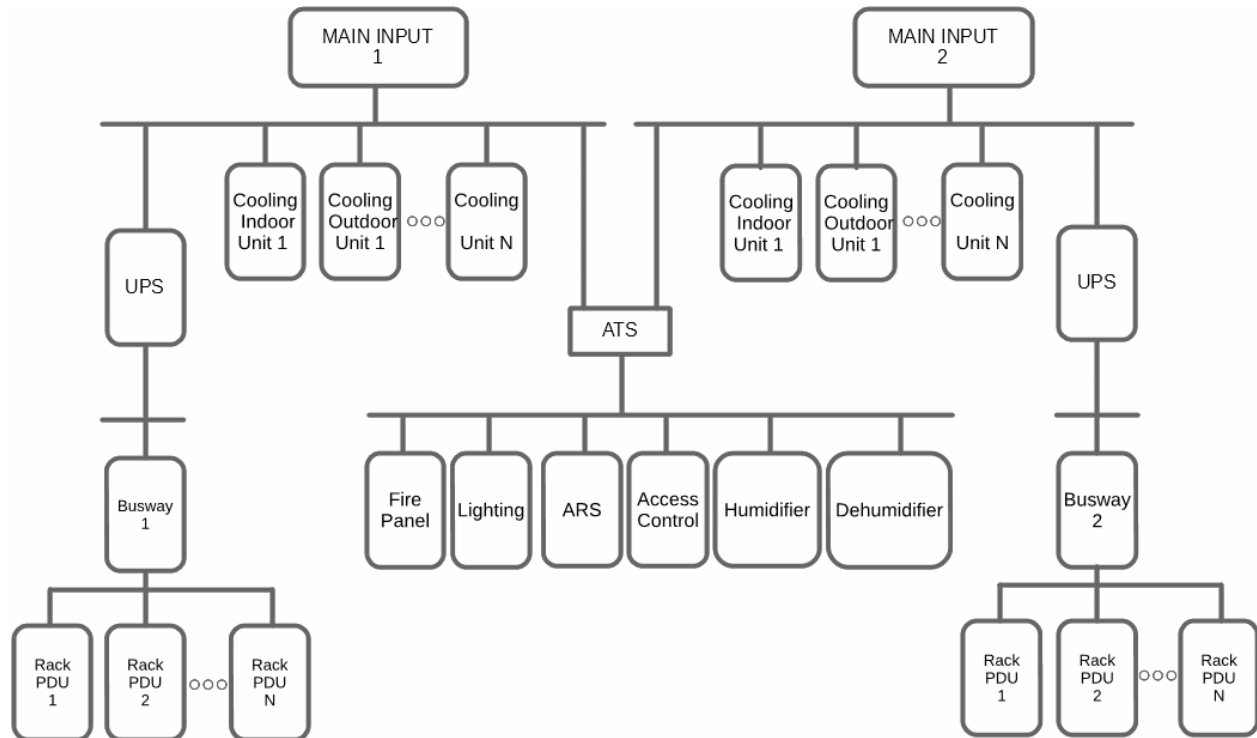

#### 3.2 Components

- **Main Input Panel:** (2N) 400V three-phase electrical panel, TN-S type, construction type. Panel incorporates 1 main input. The panel will feed all the equipment in the module as well as the condenser for the air conditioners located outside the module. The main panel includes a PM 5100 power meter and Modbus gateway for external access.
- **Uninterruptable Power System:** (2N) GALAXY VM 200KVA Part # GVMPB200KHS.
- **Busway Power Distribution:** (2N) Canalis Busway KS series, providing power distribution from the UPS to each rack
- **Rack PDU:** (56) AP8853 Rack PDU 2G, Metered, ZeroU, 32A, 230V, (36) C13 & (6) C19
- **Main Power Cabling:**
  - (2N) Power line from Main Switch Panel to UPS input
  - Internal cabling for maintenance bypass
  - Connection to Busway Distribution Unit from the UPS section
  - Power connection to the racks from the integrated breakers included in the busway power distribution unit.

- (12) Power lines to Overhead Air Conditioners
- Power lines to all internal support equipment
- **Lighting:**
  - Phillips Light Fixtures providing 300 lux are installed in each aisle in the rack space.
- **Emergency lighting:**
  - (2) Legrand Exit Sign/Emergency lighting block mounted above each door

### 3.3 Room Power Distribution

Canalis KS is medium power trunking busbar system for amperages up to 1000A. A single busway distribution bus is provided to distribute power from the UPS provided in the module to each equipment rack (a 2N power distribution busway can be optionally provided.) The Canalis busway system is a modular and upgradeable system, with quick assembly and installation. Canalis components are light and easy to handle and expose no live parts to the user for a safe and convenient experience



#### Technical characteristics

- Busbar trunking rated current: 100 to 1000A
- Tap-off units rated current: 16 to 400A
- Number of active conductors: 4+PE
- Rated insulating voltage: 690V
- Protection index: IP55
- Length of busbar trunking sections: 3m and 5m
- Surface treatment: white RAL 9001
- Regulations: compliant with IEC 61439-1 & 6

#### 3.3.1 Benefits

- Modular and upgradeable system
- Quick and easy assembly
- Flexible: possibility to install a new plug-in unit right where it is needed and without power interruption

#### Safety

- A fool-proofed system avoids a unit being installed or removed under load
- Live parts are totally inaccessible
- Tap-off units fully compatible with Canalis KT
- Light and easy to handle
- Excellent contacts: a life time guarantee

- Comprehensive range of light, strong and stylish plug-in units
- Halogen free: no emission of any fumes or toxic gases in the event of fire
- High protection index IP 55 for all types of buildings
- Dismantled, re-used and entirely recyclable

### 3.4 Grounding

The module includes an integrated grounding system. The customer will supply a ground from the external system to a grounding bar on the outside of the module. All internal components will be grounded to this bar via the internal electrical system. The module is designed to connect to a TN-S type grounding system.

## 4 Monitoring System

The Data Center Module will be provided with an integrated monitoring system that will monitor the status of the module and report the overall health and any alarms associated with the equipment inside the module.

### 4.1 EcoStruxure IT Expert

EcoStruxure IT Expert provides an efficient way for distributed IT and local edge organizations to monitor their power and cooling multi-vendor physical infrastructure equipment. Real-time monitoring, benchmarking, assessment, and instant fault notification and escalation provide the visibility and insights you need to proactively manage your IT infrastructure. This open and flexible central repository of critical information can be accessed by multiple users, and your preferred partner, from anywhere on the network, allowing quick resolution of critical infrastructure events that can adversely affect IT system availability. With the power of the cloud, you can make data-driven decisions, react to abnormal device behavior before it becomes an issue, and run analytics that will help you focus on what matters.

#### Adaptability

- **Extendable architecture** - Available node and application license keys extend the capabilities of the platform allowing it to grow to meet changing business needs.

#### Agility

- **Automatic updates and backups** - Updates and backups are automatically applied to always provide the most current solution.
- **Private networking** - Reduce IP addresses needed on the public network to manage devices, by placing them on an isolated secure network.
- **Auto-discovery** - Reduces the time needed to install and deploy physical infrastructure devices by automatically detecting manageable devices on your network.

#### Availability

- **Graphical trending analysis** - Access current and historic data for any device or group of devices. Plot and graph multiple data points in a logical correlation to visualize potential hazardous trends.
- **Centralized Alert Repository** - Access historical alerts from several appliances through one central database. Sort alerts by type, date, appliance, and/or device group.
- **Custom reporting** - Create, save and schedule user-defined reports for ease of data collection, distribution and analysis.

#### Manageability

- **Unified console** - Customizable Windows and Linux client application enables instant access from any browser or mobile device



- **Event Notifications** - Receive real-time event notifications that minimize response times to critical physical infrastructure situations, reduce mean time to repair, improve efficiency, and maximize uptime.
- **Centralized Inventory Management** - Obtain Immediate and detailed visibility of all physical infrastructure devices by geography or customizable location.
- **Cloud-based monitoring** - Maintain uptime for local edge and distributed environments and check the status of your physical infrastructure equipment from a centralized view, ensuring peace of mind whether onsite or remote.
- **Alarm Consolidation** - Reduces erroneous alarms and decreases MTTR by detecting the root cause in minutes.
- **Assessment** - Determine patterns of healthy behavior and provide a scorecard using analytics and machine learning to identify which devices require attention.
- **Benchmarking** - Compare your devices performance against the total population of similar devices in the industry.
- **Multi-vendor device support** - Extensive multi-vendor support for monitoring networked SNMP, MODBUS and Redfish devices. Enables visibility of devices through threshold alert notifications, data trending and reporting.

## Protection

- **Remote monitoring support** - Web-based service that serves as a second set of eyes into the health of a company's physical infrastructure. Experienced professionals work non-stop to provide 24-hour monitoring and to help diagnose problems before they become critical.
- **Encrypted communications** - 2048-bit RSA certificate and data is encrypted in transit using 256 bit AES encryption. EcoStruxure IT Gateway uses an outbound connection through Port 443, and only communicates to EcoStruxure IT cloud using 40.84.62.190 and 23.99.90.28.

## 4.2 Environmental Monitoring

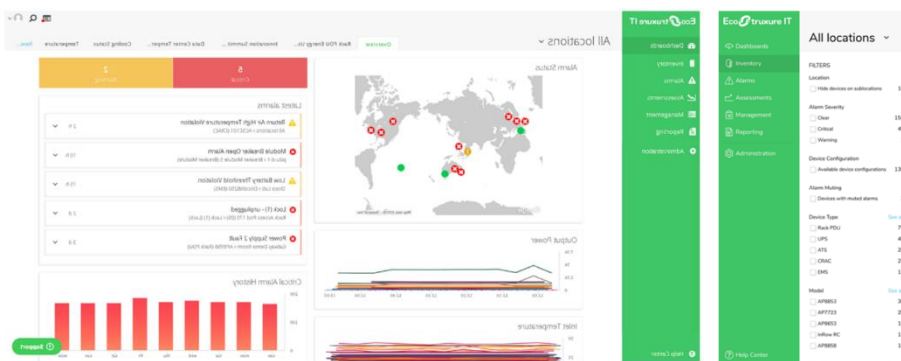

The NetBotz 750 offers an active monitoring solution designed to protect against environmental threats and unauthorized access risks that can cause downtime to IT infrastructure, in both Edge

Compute and Data Center environments. With its integrated suite of sensors, access control pods, and the newly introduced HD Camera Pod 165, the NetBotz 750 safeguards environments with surveillance and flexible alerting based on user-definable thresholds. Compute is quickly moving closer to where it is used at the Edge, increasing the risks of water damage, high temperature & humidity, fire or other conditions bringing down business-critical applications. Intentional or malicious access events not only threaten compute availability, but also leave enterprises vulnerable to costly compliance violations. The NetBotz 750 provides integrated sensing, surveillance, and badged rack-access control to help mitigate these risks through a wide array of compatible sensors, camera clip capture and storage, and configurable alarming

The Netbotz 750 system will monitor the following information inside the module:

- (1) Temperature point mounted on the front of each rack
- (1) Humidity level in the cold aisle
- Status of all the external doors
- Security cameras at each external door location
- Dry contact alarm status on the fire panel

## 5 Fire Suppression System

The fire protection system is designed to prevent, detect and extinguish possible fires inside the rooms. This will be an automatic system innocuous for people, goods and friendly environment. It will include the following equipment:

- Fire Control Panel
- Smoke Detection System (optional)
- Fire extinguishing system based on Novec 1230

### 5.1 Fire Control Panel



The fire panel controls the fire detection and extinguishing system. The panel can monitor two distinct areas, can trigger at least 2 levels of alarms, and incorporate a delay to evacuate the room before activating the extinguishing system. The system can also be activated by a manual switch attached to the panel.

This solution will implement a Honeywell Notifier RP1R Supra fire panel with following features:

- Compact and dual microprocessor central
- Easy configuration via micro switches
- Two conventional detection zones for detectors, and a third configurable for auto or manual trigger button
- Stop push button and extinction wait button
- Day / Night function with configurable delay (30 - 300 sec.) And inspection time (1 - 10 min.0
- Possible delays disabled from the keyboard
- Flow switch inputs, low pressure, monitoring door open
- Two extinction circuits, the extinction circuit 2 can be independent for pre-activation
- Countdown timer indicating the seconds left to extinction
- 40 LED display for quick identification the event
- Relays for: warning, alarm in the process of extinction, extinction canceled, extinction circuit failure, and fault relay
- Operating mode: automatic, manual and canceled
- Dry contact input for remote programmable actions as: reset the system, evacuation, mute or delay On / Off
- Removable terminal blocks in all connections
- PC state visualization software with optional remote connection
- Complies with European standards EN54-2/4 and EN12094 / 1:2003
- CE marked

(Additional control panels and features available upon request)

## 5.2 Smoke Detector

Model SD-851E photo-electronic detectors use state-of-the-art optical sensing chambers. The ability to plug these detectors into a variety of base options extends panel compatibility and application flexibility. These detectors are designed to provide open area protection and are only to be used with compatible control panels.

A bicolor LED on each detector lights red to provide a local visible alarm indication, and may also be set to flash green to indicate correct operation of the detector.

## 5.3 Extinguishing system

The automatic fire extinguishing system will be able to extinguish the fire quickly using clean extinguishing agents that don't damage the equipment to be protected. The gas release will be ordered by the fire panel at the second alarm level and once the timeframe expires. Gas can also be released manually in case the automatic system fails. Cylinders will be made of alloy steel Cr-Mo forged, seamless, with subsequent heat treatment of quenched and tempered. The system includes leakage control pursuant to regulation 842/2006/CE.

System is design with approval Transportable Pressure Equipment Directive. Hydraulic test pressure 250bar.

### 5.3.1 NOVEC 1230

NOVEC 1230 suppress fire is used in specific hazards or equipment located where an electrically nonconductive agent is required, where agent cleanup creates a problem, where extinguishing capability with low weight is a factor and where the hazard is normally occupied by personnel.

NOVEC 1230 is intended to protect the following installations:

- Petrochemical Installations
- Data Centers
- Gas Turbines
- Steam Turbine Generators
- Railway Traffic Controls
- Power Generation Plants
- Electrical Equipment
- Printing Facilities
- Electric Furnaces
- Food Packaging Facilities

#### **Features:**

- People safe at concentration levels required to suppress fire
- Zero ozone depletion potential
- Atmospheric lifetime of five days

- Colorless, with low odor with no particulate or oily residue allowing for minimal business disruption after a discharge
- Electrically non-conductive
- Space saving; quantity of NOVEC 1230 fluid needed to suppress fires typically required minimal cylinders, thus minimal space required.

**Properties:**

- Chemical name Dodecafluoro-2-methylpentan-3-one
- Chemical formula  $\text{CF}_3\text{CF}_2\text{C}(\text{O})\text{CF}(\text{CF}_3)_2$
- Compliance with ISO 14520, UNE 23570 and NFPA 2001 FK-5-1-12
- Molecular weight 316.04
- Boiling point at 1.013 bar 49.20 C
- Liquid density at 200 C 1,616 g/ml
- Critical temperature 168.660 C
- Critical pressure 18.646bar
- Vapor pressure at 200 C 0.3260bar
- Relative electrical resistance at 1atm. 250 C (N2=1.0) 2.0
- Maximum filling density 1.48 kg/l
- Design concentration for heptane 5.9%
- Flooding factor for heptane at 200C 0.8723kg/m<sup>3</sup>
- Design concentration for surface fires class A 5.3%\*
- Flooding factor for surface fires class A 0.7786kg/m<sup>3</sup>
- NOAEL 10%
- LOAEL >10%
- Ozone depletion potential 0
- Greenhouse effect potential 1

\*According to ISO 14520

**Approvals:**

NOVEC 1230 fluid is approved by the EPA and NFPA for use in fire suppression systems.

Gas, pipe, pipe fittings, bottle fittings, chrome steel diffusers, stainless diaphragms, manual pulls, system abort button, and protected local labels will be included.

## 6 Cooling



The InRow Direct Expansion unit closely couples the cooling with the IT heat load. This prevents hot air recirculation, while improving cooling predictability and allowing for a pay as you grow environment. Available in self-contained, fluid cooled, and air-cooled configurations, with or without humidity control, these products meet the diverse requirements for closet, server room, and data center cooling. IT operators looking to improve efficiency or deploy higher density equipment will benefit from the modular design of the InRow Direct Expansion products. The intelligent controls of the InRow Direct Expansion products actively adjust fan speed and refrigerant flow to match the IT heat load to maximize efficiency and address the dynamic demands of today's IT environments.

### Control and Security

- EcoStruxure™ Ready
- TLS 1.2 Security
- Touch screen color display
- Integrated network management card
- Modbus/BACnet/SNMP/Web
- Preventative maintenance alerts and alarm display
- Realtime capacity and power monitoring
- Group control

### Service and Engineering Support

- Industry leading warranty
- 1 Year parts, labor and travel
- 24x7 Technical support
- Custom engineering capabilities

### Outdoor Condensing Unit

- Minimizes service in the whitespace
- Up to 100m equivalent piping
- -25°C ambient operation
- Easy service access
- Electronic Expansion Valve
- Faster response to temperature change

### VFD Brushless Scroll Compressor

- Capacity modulation between 30-100%
- Soft start to minimize inrush current

- Maximizes partial load energy savings

### Variable Speed Hot Swappable Fans

- Active Response Controls
- Active Flow Control (AFC) compatible
- Matches IT airflow to maximize PUE
- Backup indoor fans on UPS

### Additional/Optional features

- Top or bottom connections
- Condensate pump
- Dual power supply
- Low noise kit
- Water leak detection

#### Overview

Model Name	ACRD301S - InRow DX 300mm 30kW
Includes	Installation guide, Integrated network management, Network Management Card, Optional concrete pad, User Manual

#### General

Compressor Type	Scroll
Air Discharge Patterns	Horizontal
Intake Air	Rear Return
Refrigerant load	14.97 kg
Air Flow	1604.62 l/s
Piping Material	Copper

#### Input

Number of Power Feeds	2
Nominal Input Voltage	100...120 V AC 1 phase / 200...240 V
Input Power	850 W
Minimum Circuit Amp Capacity	20.0 A
Input Frequency	50/60 Hz
Maximum Overcurrent Protection	25.0 A
Rack Height	42 U

#### Communications & Management

Control panel	Multi-function LCD status and control console
Audible Alarm	Audible and visible alarms prioritized by severity

### Physical

Maximum Height	1991.0 mm
Maximum Width	300.0 mm
Maximum Depth	1095.0 mm
Net Weight	159.98 kg

### Environmental

Operating Environment	-25 - 46 °C
Storage Temperature	-20 - 46 °C
Operating Relative Humidity	0 - 95 %
Operating Elevation	0-3000 meters
Audible noise at 1 meter from surface of unit	77.1 dB

### Conformance

Approvals	CE, UL Listed, CUL Listed
Standard warranty	1-year on-site repair or replace with factory authorized Start-Up



## 7 GALAXY VM - Uninterruptible Power Supply (UPS)

### Galaxy VM



Galaxy VM is a key component in the comprehensive Schneider Electric energy management solution for data center and industrial applications.

Galaxy VM deploys state of the art technology to lower energy cost through very high efficiency ratings and the newly innovative EConversion mode.

Galaxy VM seamlessly links to your electrical network using state of the art electrical performances like very wide input voltage range, high overload and short circuit capacity, and integrated back feed protection, providing excellent power quality.

The highly compact Galaxy VM also links in with your facility monitoring systems and smart grid requirements and offers both traditional and modular energy storage flexibility that allows tailoring of the solution to specific needs.

Galaxy VM features top and bottom cable entry without the need for an additional side cabinet, full front service access, back to the wall installation, and included start up service, making it one of the easiest UPSs in its class to deploy, install and maintain.

### **Availability**

- **Advanced electrical features** - Excellent power conditioning, very low harmonic distortion through IGBT rectifier, input power factor correction, and high power efficiency
- **Flexible Design** - Available in a wide range of configurations to suit any operating environment
- **Parallel-capacity capable** - Increases total power capacity by using multiple uninterruptible power supplies simultaneously.

- **Parallel-redundant capable** - Power the connected equipment with multiple uninterruptible power supplies to increase system redundancy

### Convenience

- **5x8 Start-up service included** - Required for full coverage of factory warranty
- **Swappable batteries** - Allows quick addition of runtime capacity or replacement of existing battery modules. Installed modules are automatically recognized by the system.
- **Top and bottom cable entry** - Allows cabling from the top and bottom without the need of additional cabinets providing footprint savings and flexibility to the installation.
- **Wheel mounted** - Allows for ease of handling during installation.

### Manageability

- **Integrated network management** - Provides complete remote monitoring and control of the UPS. Enables you to monitor remote UPS's from a web browser or industry standard Network Management System.
- **LCD graphics touch screen display** - Full color text and mimic diagrams that easily display modes of operation, systems parameters and alarms.
- **LED status indicators** - Quickly understand unit and power status with visual indicators.
- **Mimic Diagram** - Allows instant access to the status of the UPS.

### Total Cost of Ownership

- **High efficiency** - High efficiency rates that remain stable even at lower operating power levels
- **Robust operation** - No power derating in kW up to 40 degrees C or 104 degrees F.
- **Wide input voltage range** - Designed for harsh electrical environments to save battery life.

### Serviceability

- **Front-access servicing** - Simplifies installation and UPS maintenance while minimizing space requirements.
- **Multiple levels of service** - With the option of packages or individual service components, our services are structured to allow you to pick and choose what you would like APC to do for you.

### Safety

- **Internal backfeed protection** - Increase system defense from power anomalies.
- **Seismic compliance** - These all-steel enclosures meet IBC Zone 2 seismic rating.

- **Model:** GALAXY VM 200KVA
- **Rated power (kVA):** 200
- **Rated power (kW):** 180
- **UPS Redundancy:** 2N
- **SKU:** GVMPB200KHS

Overview		
Model Name	Galaxy VM 160 kVA UPS Parallel 400-400 V with Backfeed protection, Start up 5x8	Galaxy VM 200 kVA UPS Parallel 400-400 V with Backfeed protection, Start up 5x8
Includes	Built-in modbus protocol adapter , Dust filter , Installation guide , Integrated network management , Seismic compliance , Top and bottom cable entry	
General		
Bypass Connection	Built-in Static Bypass	
Bypass Voltage Tolerance	+/-10% settable from +/-4/6/8 and 10%	
Max Bypass Input Current	231 A	289 A
Bypass Protection Device	400 A	
Output		
Output Power Capacity	144.0 KW / 160.0 kVA	180.0 KW / 200.0 kVA
Max Configurable Power (Watts)	144.0 KW / 160.0 kVA	180.0 KW / 200.0 kVA
Nominal Output Voltage	400 3PH	
Output Voltage Distortion	Less than 2%	
Output Frequency (sync to mains)	50/60 Hz +/-1 Hz	
Other Output Voltages	380, 415V	
Crest Factor	Unlimited	
	Double Conversion Online	
Waveform Type	Sine wave	
Output Connections	(1) Hard Wire 4-wire (3PH + G) (Battery Backup) , (1) Hard Wire 5-wire (3PH + N + G) (Battery Backup)	
Output Voltage Tolerance	+/- 1% static and +/- 3% at 100% load step	
Overload Operation	10 minutes @ 125% and 60 seconds @ 150%	

Bypass	Built-in Static Bypass	
<b>Input</b>		
Nominal Input Voltage	400 3PH	
Input Frequency	40 - 70 Hz	
Input Connections	Hard Wire 3-wire (3PH + G)	
Input voltage range for main operations	320 - 456 (380V) V , 320 - 480 (400V) V , 320 - 498 (415V) V	
Input voltage adjustable range for mains operation	250 - 600V	
Other Input Voltages	380 , 415	
Maximum Input Current	262 A	328 A
Input Breaker Capacity	400 A	
Maximum Short Circuit Withstand (Icw)	65.0	
Input Total Harmonic Distortion	Less than 3% for full load	
Type of Input Protection Required	gL fuse	
<b>Batteries &amp; Runtime</b>		
Nominal Battery Voltage	480V	
End of Discharge Battery Voltage	384	
End of Discharge Maximum Battery Current	314 A	393 A
<b>Communications &amp; Management</b>		
Available SmartSlot™ Interface Quantity	2	
Audible Alarm	Audible and visible alarms prioritized by severity	
Emergency Power Off (EPO)	Yes	
<b>Physical</b>		
Maximum Height	1970.0 mm	
Maximum Width	1052.0 mm	
Maximum Depth	854.0 mm	
Net Weight	699.0 kg	724.0 kg
Color	White	
<b>Environmental</b>		
Operating Environment	0 - 40 °C	

Operating Relative Humidity	0 - 95 %	
Operating Elevation	0-999.9 meters	
Storage Temperature	-25 - 55 °C	
Storage Relative Humidity	0 - 95 %	
Storage Elevation	0-14763.6 meters	
Audible noise at 1 meter from surface of unit	65.000 dB	
Online Thermal Dissipation	19650.000 BTU/hr	24570.000 BTU/hr
Protection Class	IP 20	
<b>Conformance</b>		
Approvals	C-tick , CE , EN/IEC 62040-1 , EN/IEC 62040-2 , EN/IEC 62040-3 , IBC 2012 and CBC2013 to Sds=2.02g , OSHPD , RCM , UL 1778 , VFI-SS-111	
Standard warranty	1 year on-site repair or replace with factory authorized Start-Up	

## 8 Racks - NetShelter SX/SV



APC NetShelter rack enclosure maximizes flexibility with a progressive, non-proprietary feature-set as well as an extensive line of scalable accessory products to address current needs and adapt to future technology trends. APC NetShelter® rack systems provide a progressive feature-set available in a vendor-neutral rack environment while allowing the user the flexibility to quickly adapt to emerging trends. NetShelter racks and enclosures support can adapt of any type of applications.

These enclosures are designed to meet current IT market trends and applications ranging from high density computing and networking to broadcast and audio-video. With a strong focus on cooling, power distribution, cable management and environmental monitoring, the NetShelter SX rack enclosure provides a reliable rack-mounting environment for mission-critical equipment.

The NetShelter SV is the IT enclosure you have become familiar with from Schneider Electric but now with basic functionality and features provided as a cost-effective solution. The NetShelter SV maintains a strong focus on cooling, power distribution, and cable management to provide a reliable rack-mounting environment for mission-critical equipment but with optional features such as side panels or even an unassembled option that reduces the cost of the base enclosure.

### Convenience

- **Cable access openings with pre-installed brushes** - Large cable access slots in the roof provides access for overhead cable egress. The bottom design allows for unobstructed cable access through a raised floor. Roof includes openings with brush strips pre-installed in locations biased towards the front of the enclosure to allow for data cable pass through and provisions for air containment.
- **Half-height side panels and option with brush strips for pass-through** - Half-height quick release side panels reduce size and weight for easy handling and access to equipment. Side panels are lockable utilizing a single key with the doors. Now available are side panel options integrated with pass-through holes and brush strips for routing cabling to adjacent racks in a row while still maintaining proper airflow.
- **Perforated front door with curved profile** - Perforated front and rear doors provide ample ventilation for servers and networking equipment. Front door perforated area is optimized with a curved profile to provide greater surface area and allowance of more perforation coverage and higher perforation rating.
- **Quick release doors** - Front door can be moved to the opposite side or interchanged with rear doors. Doors are easily removed with simple lift-off design.

### Agility

- **Adjustable mounting rails with captive hardware and rapid alignment** - The vertical mounting rails can be adjusted in 1/4 in (6.4 mm) increments covering virtually any mounting requirement for IT equipment. Easy alignment feature integrated into the enclosure mounting rail and side brace for quick alignment verification without the use of

tools to verify alignment. U positions are numbered front and back for rapid installation of equipment.

- **Integrated joining hardware with multiple width enclosure alignment** - Enclosures include pre-installed joining hardware to join enclosures in a row and provide additional stability to the enclosure. The pre-installed joining hardware includes holes for joining to an adjacent enclosure at 600mm centers or 24in centers depending upon the floor layout.
- **Low-profile castors and adjustable leveling feet from underneath or above** - Enclosures are shipped standard with both leveling feet and castors. Leveling feet can be quickly adjusted using a screwdriver or drill, eliminating the need to reach underneath with a wrench.
- **Pre-installed full-enclosure height rear accessory channels** - Integrated and adjustable rear accessory channel provides zero U mounting locations for tool less accessories. Each channel has two mounting bays to support a combination of up to four accessories such as PDUs and vertical cable organizers. 1070mm (42in), 825mm (32 in), and deep enclosures and networking enclosures include two channels. 1200mm (48in) deep enclosures include four channels. Channels are pre-installed at the factory in the rear of the enclosure but can be moved to other locations of the enclosure along the side brace to resituate cable management where it is needed most.
- **Split rear doors** - Split rear doors improve access and serviceability to rear of rack mounted equipment. The split rear doors help to maximize floor space. Only 11 inches (279 mm) of clearance is required behind the enclosures to allow for door swing.

## Safety

- **Designed for enhanced structural stability** - A proven frame design, heavy-gauge mounting rails.

- **Model:** [[Value not found]]
- **Description:** [[Value not found]]
- **Number of racks:** 28

Rack Model	AR2480	AR2580	AR3100	AR3150	AR3300	AR3350
Overview						
Includes	Baying hardware, Key(s) , Keyed-alike doors and side panels , Leveling feet , Mounting Hardware , Pre-installed casters , Side Panels					
Physical						
Net Weight	130.5 kg	139.5 kg	125.09 kg	155.96 kg	134.09 kg	161.37 kg
Maximum Height	2057.0 mm		1991.0 mm			
Maximum Width	800.0 mm		600.0 mm	750.0 mm	600.0 mm	750.0 mm
Maximum Depth	1060 mm	1200 mm	1070.0 mm		1200.0 mm	
Rack Height	42 U	42 U	42 U	42 U	42 U	42 U
Color	Black					

Vertical Posts	18 gauge	16 gauge			
Front Door	16 gauge				
Rear Door	16 gauge	18 gauge	16 gauge	18 gauge	16 gauge
Roof	19 gauge	18 gauge			
EIA Mounting Rails	14 gauge				
Side Panels	18 gauge				
<b>Conformance</b>					
Approvals	UL 2416, UL 60950-1, EIA-310E				
Standard warranty	5-year repair or replace				
<b>Offer Sustainability</b>					
RoHS	Compliant				
REACH	REACH: Contains No SVHCs				
Other Environmental Compliance	China RoHS				
Sustainable Offer Status	Green Premium product				

Rack Model	AR2487	AR2587	AR3107	AR3157	AR3307	AR3357
<b>Overview</b>						
Includes	Baying hardware, Key(s) , Keyed-alike doors and side panels , Leveling feet , Mounting Hardware , Pre-installed casters , Side Panels					
<b>Physical</b>						
Net Weight	143.8 kg	152.8 kg	138.23 kg	169.09 kg	149.56 kg	185.45 kg
Maximum Height	2324 mm	2324 mm	2258.0 mm			
Maximum Width	800.0 mm		600.0 mm	750.0 mm	600.0 mm	750.0 mm
Maximum Depth	1060 mm	1200 mm	1070.0 mm		1200.0 mm	
Rack Height	48 U	48 U	48 U	48 U	48 U	48 U
Color	Black					
Vertical Posts	18 gauge		16 gauge			
Front Door	16 gauge					
Rear Door	16 gauge		18 gauge	16 gauge	18 gauge	16 gauge
Roof	19 gauge	18 gauge				
EIA Mounting Rails	14 gauge					



Side Panels	18 gauge
Conformance	
Approvals	UL 2416, UL 60950-1, EIA-310E
Standard warranty	5-year repair or replace
Offer Sustainability	
RoHS	Compliant
REACH	REACH: Contains No SVHCs
Other Environmental Compliance	China RoHS
Sustainable Offer Status	Green Premium product

## 8.1 Rack Power Distribution

APC Metered Rack Power Distribution Units (PDUs) provide active metering to enable energy optimization and circuit protection. User-defined alarm thresholds mitigate risk with real-time local and remote alerts to warn of potential circuit overloads. Metered Rack PDUs provide power utilization data to allow Data Center Managers to make informed decisions on load balancing and right sizing IT environments to lower total cost of ownership. Users can access and configure Metered Rack PDUs through secure Web, SNMP, or Telnet Interfaces which are complimented by APC Centralized Management platforms using StruxureWare Data Center Expert, Operations, Capacity, and Energy Efficiency.

AP8000 series Metered Rack PDUs include real power monitoring, a temperature/humidity sensor port, locking IEC receptacles, and ultra-low profile circuit breakers.

Features:

- Load indicator LED. Indicates overload and warning conditions based on the user-defined alarm thresholds. Alerts users of potential overloaded circuits.
- Integrates with StruxureWare Data Center Expert. An IT-ready, scalable access monitoring system that collects, organizes, and distributes critical alerts, surveillance video and key information, providing a unified view of complex physical infrastructure environments from anywhere on the network
- Flash Upgradeable. Quickly and easily upgrade firmware via network download for future product enhancements. Eliminates the need to replace products already installed in the field when new features are released. (Note: Networked units only)
- Alarm Thresholds. Define alarm thresholds in order to avoid overloaded circuits. Network and visual alarms inform the user of possible problems. (Note: Only available on units with the current monitoring capabilities. Please see SKU specifications for availability)
- Local Current Monitoring Display. The aggregate current draw per rack PDU is displayed on the unit via a digital display. The local digital display helps installers avoid overloaded circuits by providing a visible warning when the current draw is close to the maximum amperage draw of the strip. (Available on designated SKUs only)

- **Remote Management Capabilities.** Full-featured network management interfaces that provide standards-based management via Web, SNMP, and Telnet. Allows users to access, configure, and manage units from remote locations to save valuable time. Associated with this feature is the ability to quickly and easily upgrade the firmware via network download to installed units for future product enhancements.



### Overview

Model Name	AP8853
Includes	Installation guide, Rack Mounting brackets, Safety guide, Serial configuration cable

### Output

Nominal Output Voltage	230V
Maximum Total Current Draw per Phase	32 A
Output Connections	(36) IEC 320 C13 (Battery Backup), (6) IEC 320 C19 (Battery Backup)
Always on Outlets	0
Overload Protection	Yes

### Input

Nominal Input Voltage	200V, 208V, 230V
Input Frequency	50/60 Hz
Input Connections	IEC 309 32A 2P+E
Cord Length	3 meters
Number of Power Cords	1
Acceptable Input Voltage	220-240 VAC
Maximum Line Current per phase	32 A

Maximum Input Current per phase	32 A
Load Capacity	0 VA

### Physical

Net Weight	6.93 kg
Maximum Height	1791.0 mm
Maximum Width	56.0 mm
Maximum Depth	44.0 mm
Shipping Weight	8.56 kg
Shipping Height	2000.0 mm
Shipping Width	162.0 mm
Shipping Depth	107.0 mm
Color	Black

### Environmental

Operating Environment	-5 - 45 °C
Operating Relative Humidity	5 - 95 %
Operating Elevation	0-3000 meters
Storage Temperature	-25 - 65 °C
Storage Relative Humidity	5 - 95 %
Storage Elevation	0-15000 meters

### Conformance

Approvals	IEC 60950, VDE
Standard warranty	2 years repair or replace

### Sustainable Offer Status

RoHS	Compliant
REACH	REACH: Contains No SVHCs
Battery Directive	Compliant
Battery Notes	Battery Notes

## 9 Exclusions

The following list gives the limit of our scope of supply. All works listed hereafter are excluded from this proposal.

### **General:**

- Any item not specifically listed in the proposal
- Freight to the final site
- Unloading of the module into its final position
- Project management services

### **Civil works:**

- Any outdoor and indoor civil works (e.g. trenches, preparation of foundations, concrete slabs, fireproof walls, doors, holes, stairs...)
- Any opening or drilling in the building existing walls and roof
- Any scaffolding, builders work or allied tradesman work
- Any ceiling or overhead plenum
- Installation of condensers on external slab
- Attachment of piping between condensers and module
- Any steps or ramps required for doorways

### **Data cabling:**

- Any IT cabling and fiber optics installation

### **Electrical cabling:**

- Any electrical installation work outside the prefabricated building solution
- Any digging, trenches and soil preparation for fuel tank and piping network installation
- The supply and installation of the incoming LV electrical supply from the gensets
- The supply and installation of the incoming LV electrical supply from the normal source

### **Electrical equipment:**

- Emergency gensets including fuel tanks