

EcoStruxure Modular Data Center – 25’ Module

42 KW / 50Hz All in One Datacenter Module

Technical Specification

Version 3.1



Project name: EDGE BASE DESIGN
Customer 0
Date 22/04/2021

BFO # PFMIEJ042W1R007B
Revision 1

Table of Contents



1	Introduction.....	4
1.1	Context	4
1.2	Main benefits	4
1.3	Scope of work.....	4
2	Prefabricated Datacenter.....	5
2.1	Introduction	5
2.2	Concept and Dimensions for Prefabricated Module.....	5
2.2.1	Prefabricated Solution for 7 Racks.....	5
2.3	Structural design.....	6
2.3.1	Steel Frame Design.....	6
2.3.2	Wall design	6
2.3.3	Floor	7
2.3.4	Doors	7
2.3.5	Cable Glands.....	8
2.3.6	Air Renovation System (optional).....	9
2.4	Technical Specifications	9
2.4.1	Shock-load.....	9
2.4.2	Wind load.....	9
2.4.3	Roof load	9
2.4.4	Floor load.....	9
2.4.5	External temperature range.....	10
2.4.6	Internal environmental conditions.....	10
2.4.7	Fire resistance	10
2.4.8	Painting.....	10
2.5	Mounting Pad support.....	10
2.6	Lifting elements.....	10
2.7	Technical Specifications	11
2.8	Standards	11
3	Electrical System	13
3.1	Conceptual Single Line Diagram	13
3.2	Components	13
3.3	Room Power Distribution	14
3.3.1	Benefits.....	14
3.4	Grounding	15
4	Monitoring System	16
4.1	EcoStruxure IT Expert	16
4.2	Environmental Monitoring.....	17
5	Fire Suppression System.....	19
5.1	Fire Control Panel.....	19
5.2	Smoke Detector	20

5.3	Extinguishing system	20
5.3.1	NOVEC 1230.....	20
6	Cooling	22
7	GALAXY VS - Uninterruptible Power Supply (UPS) ...	24
8	Racks - NetShelter SX/SV	28
8.1	Rack Power Distribution	31
9	Exclusions	34

1 Introduction

1.1 Context

The purpose of the document is to introduce and present the technical specification of the EcoStruxure Modular Data Center 41,72 kW All in One Datacenter Module offered by Schneider Electric.

EcoStruxure Modular Data Center solution provides a fully functional Data Center inside a prefabricated module, with complete infrastructure including: cooling, power, structural protection, fire protection, monitoring, access control, etc., within a secure environment design, comprising a modular and flexible approach, in a generous space.

This solution consists of a constructive solution of equivalent quality to a proper room dedicated to IT, including the entire necessary infrastructure.

The environment has been designed to provide the following qualities:

- Usability for IT and technical operations
- Security: Mechanical, Electrical, Cooling
- High quality, robust structure
- Reduced time to acquire and deploy

1.2 Main benefits

Prefabricated Datacenter Modules are the latest trend in the datacenter industry intended to decrease the time to acquire and deploy new datacenter capacity, improve the predictability and reliability of a new datacenter build and reduce upfront and ongoing capital expenditures.

All equipment in the proposed module are pre-installed and tested in our factories, reducing on-site construction risks and reducing time allocated for site works and commissioning.

Schneider Electric is a worldwide market leader in the data center business worldwide with complete integrated solutions including prefabricated modules, UPS, power distribution, cooling, software, monitoring, and enclosures. Our installed base gives us a thorough knowledge of data center market evolution, future needs and an understanding of business challenges.

1.3 Scope of work

This proposal covers a complete prefabricated module

This document mainly covers the following topics:

- Enclosure structure and design
- UPS
- Electrical distribution
- Cooling
- IT Infrastructure (Racks, rack and row level power distribution)
- Fire suppression and detection
- Monitoring

2 Prefabricated Datacenter

2.1 Introduction

The following proposal is for an All in One prefabricated Module that is a separate prefabricated structure. This module provides the complete functionality for a 41,72 KW Datacenter environment providing power, cooling, and access for an IT environment.

2.2 Concept and Dimensions for Prefabricated Module

2.2.1 Prefabricated Solution for 7 Racks



Solution for 7 racks includes:

- 1 x 25' Module: 25' (7.62m) x 10.5' (3.2m) x 11.8' (3.6m) (LxWxH)
- Uninterruptible Power Supply – GALAXY VS 50KVA
- Busbar Canalis distributing power to each IT rack.
 - Input Voltage 400 VAC, Output Voltage 400 VAC
- Electrical configuration
 - General power, lights and HVAC on non-critical power
 - IT racks on UPS power (UPS GALAXY VS 50KVA)
- Cooling
 - (4) WMF0661, N+1 configuration
 - See cooling description for external condensers rated temperature ambient
 - Humidifier with controller - Not included
- Racks – NetShelter SX Enclosures
 - (7) [[Value not found]] - [[Value not found]] (WxDxH),
- METERED Rack PDU – (7) AP8853 - Rack PDU 2G, Metered, ZeroU, 32A, 230V, (36) C13 & (6) C19
- Netbotz 750 environmental monitoring system monitoring the following
 - Internal temperature

- Internal humidity
 - Leak detection
 - External Door Status
 - Security camera monitoring
- Automatic fire extinguishing system
 - Cable glands for power, refrigerant piping, and fiber entrance into the module

Options:

- Automatic transfer switch included for generator input as optional

2.3 Structural design

The EcoStruxure Modular Data Center is made of a welded structural steel frames enclosed by a modular wall panel system. The special features of the insulated panels provide the right Data Center environment.

- EI60 per EN13501 (all components).
- Coefficient of Thermal Transmission of < 0,47 W/m2K
- Certification on equivalent enclosure IP55 per EN 60529

2.3.1 Steel Frame Design

The frame consists of fully welded structural steel members. EcoStruxure Modular Data Center frame is composed of the following parts:

- Base-Skid with 6mm sheet metal flooring and 3 lift points per side.
- Constructed of frames made from welded tubular steel.

External dimensions ⁽¹⁾	Imperial	Metric
Length	25'	7.620 mm
Width	10.5'	3.200 mm
Height	11.8'	3.600 mm

⁽¹⁾ 2% tolerance

2.3.2 Wall design

EcoStruxure Modular Data Center offers high levels of thermal and fire protection. Rockwool panels close the area inside the module providing a clean area proper for a DC.

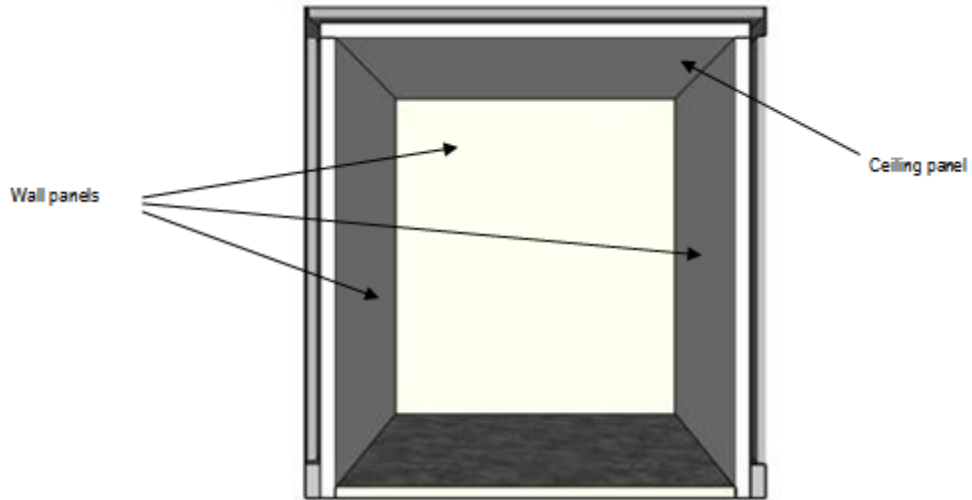

Panels will be installed on the walls and ceiling and will be composed by a sandwich of materials with fire resistance and thermal insulating to resist high temperatures and provide a watertight enclosure. The sandwich will be covered by one layer of galvanized steel sheet (0,6 mm), joined by continuous weld panel to panel.

Main features:

- Thickness: 80 mm = 3.1"
- Thermal resistance, K1 (panel): 0,470 W/m²K
- Fire resistance: EI60, per EN 13501-2

Final Inner dimensions ⁽¹⁾	Imperial	Metric
Length	294"	7.460 mm
Width	119"	3.040 mm
Height	118"	3.000 mm

⁽¹⁾ 2% tolerance

2.3.3 Floor

EcoStruxure Modular Data Center is equipped with 1.5" (nominal) thick marine plywood flooring finished with metal diamond plate. The 6mm floor allows equipment to be mechanically fixed via screws and support profiles.

2.3.4 Doors

The SmartShelter Container includes two EI90 standard door. This door fulfills all regular requirements and requirements as an emergency exit. It is made of steel and is painted and protected against rust.

Doors are RC2 break-in resistance level in accordance with EN 1627/1630.

All Doors supplied with:

LEAF	
Steel plate finishes	1,2 mm
High-density fiberboard for fire protection with EI 90	60 mm
Total thickness	63 mm
FRAMEWORK	
Steel profile	1,5 mm
Intumescent seal	1,9 mm
FITTINGS & MECHANISMS	
Steel bearing hinges	3 u
PVC & steel handle with lock door	
Electric strike	
Quick push panic bar	
Self-closing system	

Dimensions:

	Width		Height
	Simple door	Double door	
External dimensions	1.280 mm 50,4"	1.740 mm 68,5"	2.380 mm 93,7"
Internal dimensions	1.100 mm 43,3"	1.600 mm 63"	2.200 mm 86,6"

2.3.5 Cable Glands

Roxtec cable glands will be installed at all cabling and piping interface points that enter or exit the module. Cable glands provide thermal, fire, and water protection for the module. The cable gland is easily configurable to adapt to the number and dimensions of cables and pipes that enter the module since it uses a compression unit inside of frame.

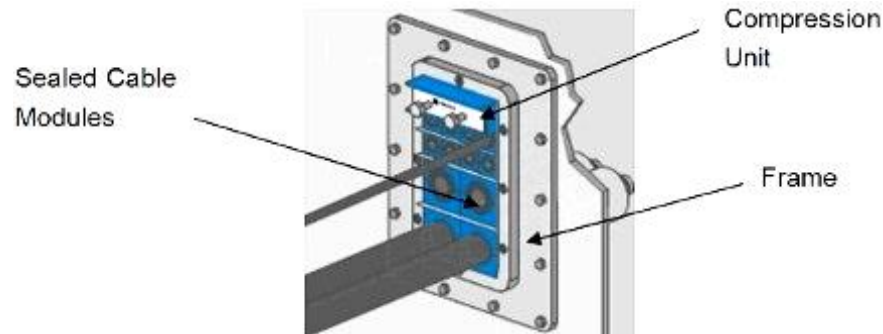

2.3.6 Air Renovation System (optional)

The Air Renovation System (ARS) is a ventilation unit designed to meet air renovation requirements to comply with local regulations in Prefabricated Data Centers where IT equipment and UPS batteries are installed.

To provide the proper airflow, an EC fan intakes outside air via a grille attached to G4 and G7 filters. In accordance with ASHRAE, IT spaces require air filtering (minimum F7 / MERV13).

UNIT COMPONENTS	ARS (CE)
EC Radial fan	✓
Air filter G4 efficiency (MERV 8)	✓
Air filter F7 efficiency (MERV 13)	✓
Air filter F9 efficiency (MERV 16) ⁽¹⁾	optional
Sand trap	optional
Electrical heater (antifreeze)	optional
Timer	optional
Door switch	optional
VOC control (Volatile organic compound)	optional
H ₂ control sensor	optional
Combined H ₂ + VOC sensor	optional
Change power supply	under request

✓ Standard component

× Not available

(1): Other filters under request

2.4 Technical Specifications

The module is designed to provide a controlled environment suitable for equipment and personnel. The units will be capable for delivery and installation on site without any permanent deformation or failure.

2.4.1 Shock-load

Building module units can withstand normal transportation conditions before installation on the site, without deformation or damage. Shock of 2g, 10 millisecond duration for transport conditions per IEC 60068-2-64.

2.4.2 Wind load

The module can withstand non-sustained wind speeds up to 160km/h per Eurocode EN1991-1-4, applied to the walls of the enclosure.

2.4.3 Roof load

The module can withstand snow load of 245 kg/m² on roof (14,600 kg total)

2.4.4 Floor load

The module can withstand floor loads up to 1.000kg/m² across the entire floor structure. Specific bracing for heavy components such as battery cabinets is provided.

2.4.5 External temperature range

See below cooling technical specifications

2.4.6 Internal environmental conditions

The internal conditions will maintain ASHRAE TC 9.9 recommended temperature and humidity ranges.

2.4.7 Fire resistance

1 hour fire resistant construction for enclosure walls, roof, and doors is provided.

2.4.8 Painting

EcoStruxure Modular Data Center have two primer epoxy and two final polyurethane coats in a RAL 9003 standard color. This surface treatment provides C3 corrosion protection with medium durability (5 to 15 years).

Per ISO 12944 standard, a C3 protection works well in exterior environments with average sulfide oxide (IV) contamination level, inshore areas of low salinity and interior environment with high humidity and certain air contamination.

2.5 Mounting Pad support

The module must be placed on a foundation with continuous support for the perimeter walls. The foundation must be level and engineered to support the final total load of the installed and operational module.

2.6 Lifting elements

The module includes 6 lift points (3 on each side). Only these attachment points may be used to lift or move the module. All 6 must be used simultaneously. Module is equipped with appropriate lifting points.

- Lift top corner fittings vertically by means of spreaders fitted with hooks, shackles or twist locks
- Lift at bottom corner fitting using slings with terminal fittings at any angles between vertical and 55 degrees to the horizontal.

- Center of gravity must be considered to keep the module level while lifting.

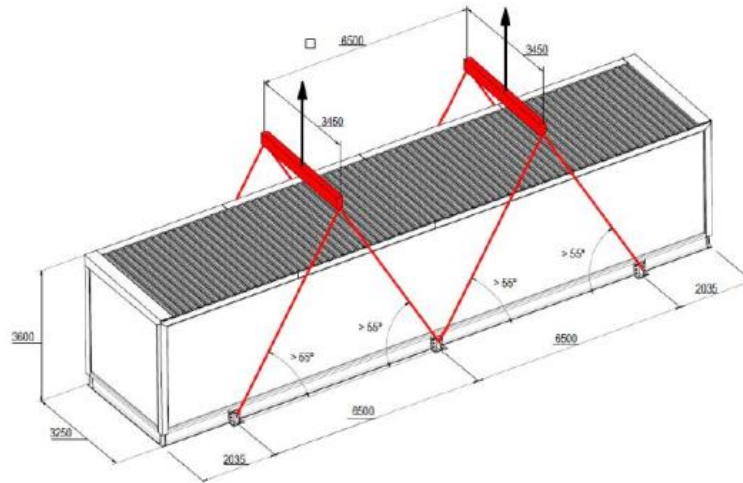

2.7 Technical Specifications

- Development and assembly of S275JR steel in laminated profiles, plates, and tubular profiles for skid formation and support structure of walls and ceilings.
- Blasting material up to grade SA 2 ½ with a layer of antioxidant primer of 30 microns and subsequent surface treatment of class C3 RAL 9003.
- SKID profile IPE360, IPE300, IPE120 and 6mm sheet on the floor.
- Frames of tubular steel 70x70x4mm, mechanically welded.
- Designed for insulation with a polyurethane layer of ≥ 30 mm under the floor in the base.
- 6 lifting anchor points (lifting brackets) with M30 bolts.
- 80mm Rockwool panels with concealed attachment points, thermal insulation with Coefficient of Thermal Transmission of $< 0,47$ W/m²K, EI60, outer sheet metal 0.6mm, surface treatment C3.
- Wall construction involves complete covering of the wall and roof support structure to eliminate any thermal bridge.
- Finishing profiles 0.6mm with surface treatment C3.
- Single-leaf doors with height (2200mm) and three width options (1100mm, 1020mm, and 900mm). Include panic bar, electronic monitoring, and automatic closure.

2.8 Standards

Metallic Frame

- EN 1990 Eurocode - Basis of structural design
- EN 1090-2 Execution of steel structures - Part 2: Technical requirements for steel structures
- EN 1991 Eurocode 1 - Actions on structures
- EN 1993 Eurocode 3 - Design of steel structures

- EN 10025 Hot rolled products of structural steels
- ISO 15607 Specification and qualification of welding procedures for metallic materials - general rules
- ISO 15609 Specification and qualification of welding procedures for metallic materials — Welding procedure specification
- EN 9606 Qualification testing of welders

Surface treatment

- ISO 12944 Corrosion protection of steel structures by protective paint systems
- ISO 9223 Corrosive atmospheres

Insulation Walls

- EN 13501 Fire classification of construction products and building elements.
- EN 1364 Fire resistance tests for non-loadbearing elements. Walls
- EN 10169 Continuously organic coated (coil coated) steel flat products.
- EN 14509 QC. Self-supporting double skin metal faced insulating panels. Factory made products. Specifications
- EN 10346 Structural adhesives. Determination of the pot life (working life) of multi-component adhesives
- EN 13162 Thermal insulation products for buildings. Factory made mineral wool (MW) products.

Doors

- EN 13501 Fire classification of construction products and building elements.
- EN 12425 Industrial, commercial and garage doors and gates. Resistance to water penetration. Classification.
- EN 12489 Industrial, commercial and garage doors and gates. Resistance to water penetration. Test method.
- EN 1191 Windows and doors. Resistance to repeated opening and closing.

3 Electrical System

Following is the description of the electrical system provided inside the module.

3.1 Conceptual Single Line Diagram

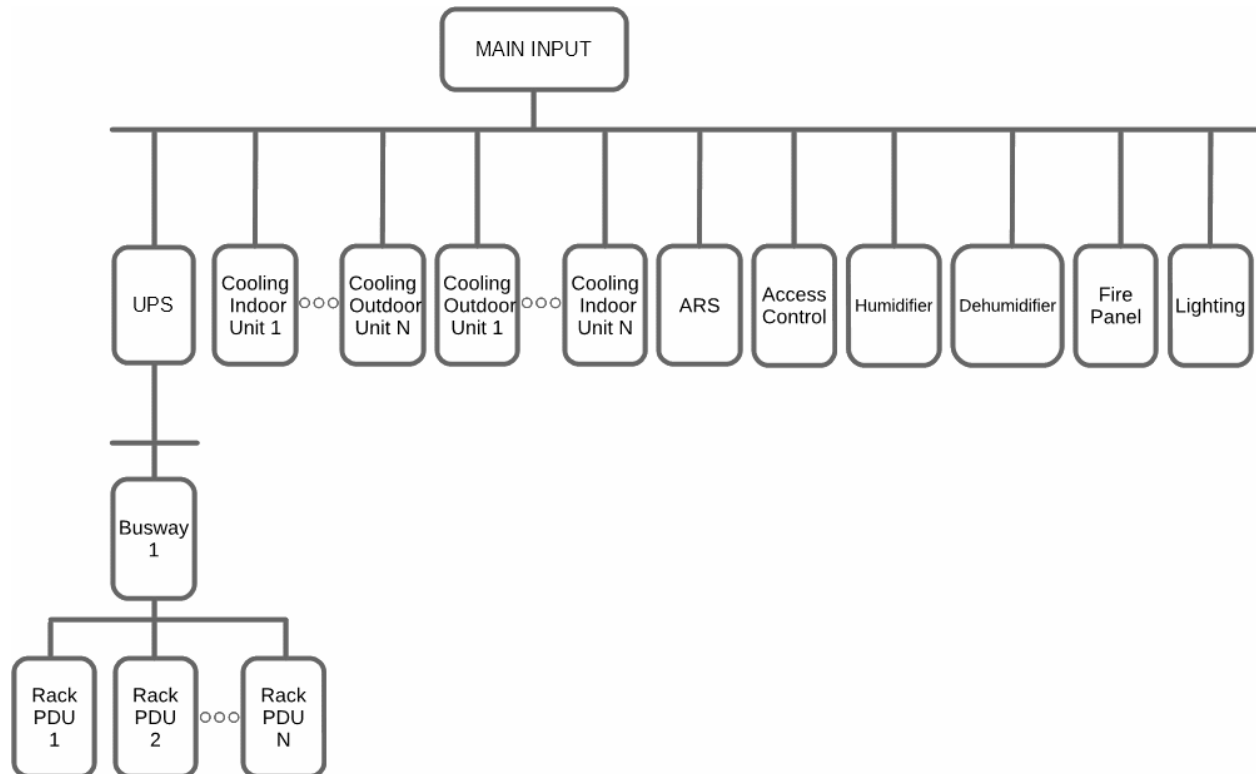

3.2 Components

- **Main Input Panel:** (N) 400V three-phase electrical panel, TN-S type, construction type. Panel incorporates 1 main input. The panel will feed all the equipment in the module as well as the condenser for the air conditioners located outside the module. The main panel includes a PM 5100 power meter and Modbus gateway for external access.
- **Uninterruptable Power System:** (N) GALAXY VS 50KVA Part # GVSUPS50KB4HS.
- **Busway Power Distribution:** (N) Canalis Busway KS series, providing power distribution from the UPS to each rack
- **Rack PDU:** (7) AP8853 Rack PDU 2G, Metered, ZeroU, 32A, 230V, (36) C13 & (6) C19
- **Main Power Cabling:**
 - (N) Power line from Main Switch Panel to UPS input
 - Internal cabling for maintenance bypass
 - Connection to Busway Distribution Unit from the UPS section

- Power connection to the racks from the integrated breakers included in the busway power distribution unit.
- (4) Power lines to Overhead Air Conditioners
- Power lines to all internal support equipment
- **Lighting:**
 - Phillips Light Fixtures providing 300 lux are installed in each aisle in the rack space.
- **Emergency lighting:**
 - (1) Legrand Exit Sign/Emergency lighting block mounted above each door

3.3 Room Power Distribution

Canalis KS is medium power trunking busbar system for amperages up to 1000A. A single busway distribution bus is provided to distribute power from the UPS provided in the module to each equipment rack (a 2N power distribution busway can be optionally provided.) The Canalis busway system is a modular and upgradeable system, with quick assembly and installation. Canalis components are light and easy to handle and expose no live parts to the user for a safe and convenient experience



Technical characteristics

- Busbar trunking rated current: 100 to 1000A
- Tap-off units rated current: 16 to 400A
- Number of active conductors: 4+PE
- Rated insulating voltage: 690V
- Protection index: IP55
- Length of busbar trunking sections: 3m and 5m
- Surface treatment: white RAL 9001
- Regulations: compliant with IEC 61439-1 & 6

3.3.1 Benefits

- Modular and upgradeable system
- Quick and easy assembly
- Flexible: possibility to install a new plug-in unit right where it is needed and without power interruption

Safety

- A fool-proofed system avoids a unit being installed or removed under load
- Live parts are totally inaccessible
- Tap-off units fully compatible with Canalis KT

- Light and easy to handle
- Excellent contacts: a life time guarantee
- Comprehensive range of light, strong and stylish plug-in units
- Halogen free: no emission of any fumes or toxic gases in the event of fire
- High protection index IP 55 for all types of buildings
- Dismantled, re-used and entirely recyclable

3.4 Grounding

The module includes an integrated grounding system. The customer will supply a ground from the external system to a grounding bar on the outside of the module. All internal components will be grounded to this bar via the internal electrical system. The module is designed to connect to a TN-S type grounding system.

4 Monitoring System

The Data Center Module will be provided with an integrated monitoring system that will monitor the status of the module and report the overall health and any alarms associated with the equipment inside the module.

4.1 EcoStruxure IT Expert

EcoStruxure IT Expert provides an efficient way for distributed IT and local edge organizations to monitor their power and cooling multi-vendor physical infrastructure equipment. Real-time monitoring, benchmarking, assessment, and instant fault notification and escalation provide the visibility and insights you need to proactively manage your IT infrastructure. This open and flexible central repository of critical information can be accessed by multiple users, and your preferred partner, from anywhere on the network, allowing quick resolution of critical infrastructure events that can adversely affect IT system availability. With the power of the cloud, you can make data-driven decisions, react to abnormal device behavior before it becomes an issue, and run analytics that will help you focus on what matters.

Adaptability

- **Extendable architecture** - Available node and application license keys extend the capabilities of the platform allowing it to grow to meet changing business needs.

Agility

- **Automatic updates and backups** - Updates and backups are automatically applied to always provide the most current solution.
- **Private networking** - Reduce IP addresses needed on the public network to manage devices, by placing them on an isolated secure network.
- **Auto-discovery** - Reduces the time needed to install and deploy physical infrastructure devices by automatically detecting manageable devices on your network.

Availability

- **Graphical trending analysis** - Access current and historic data for any device or group of devices. Plot and graph multiple data points in a logical correlation to visualize potential hazardous trends.
- **Centralized Alert Repository** - Access historical alerts from several appliances through one central database. Sort alerts by type, date, appliance, and/or device group.
- **Custom reporting** - Create, save and schedule user-defined reports for ease of data collection, distribution and analysis.

Manageability

- **Unified console** - Customizable Windows and Linux client application enables instant access from any browser or mobile device

- **Event Notifications** - Receive real-time event notifications that minimize response times to critical physical infrastructure situations, reduce mean time to repair, improve efficiency, and maximize uptime.
- **Centralized Inventory Management** - Obtain Immediate and detailed visibility of all physical infrastructure devices by geography or customizable location.
- **Cloud-based monitoring** - Maintain uptime for local edge and distributed environments and check the status of your physical infrastructure equipment from a centralized view, ensuring peace of mind whether onsite or remote.
- **Alarm Consolidation** - Reduces erroneous alarms and decreases MTTR by detecting the root cause in minutes.
- **Assessment** - Determine patterns of healthy behavior and provide a scorecard using analytics and machine learning to identify which devices require attention.
- **Benchmarking** - Compare your devices performance against the total population of similar devices in the industry.
- **Multi-vendor device support** - Extensive multi-vendor support for monitoring networked SNMP, MODBUS and Redfish devices. Enables visibility of devices through threshold alert notifications, data trending and reporting.

Protection

- **Remote monitoring support** - Web-based service that serves as a second set of eyes into the health of a company's physical infrastructure. Experienced professionals work non-stop to provide 24-hour monitoring and to help diagnose problems before they become critical.
- **Encrypted communications** - 2048-bit RSA certificate and data is encrypted in transit using 256 bit AES encryption. EcoStruxure IT Gateway uses an outbound connection through Port 443, and only communicates to EcoStruxure IT cloud using 40.84.62.190 and 23.99.90.28.

4.2 Environmental Monitoring

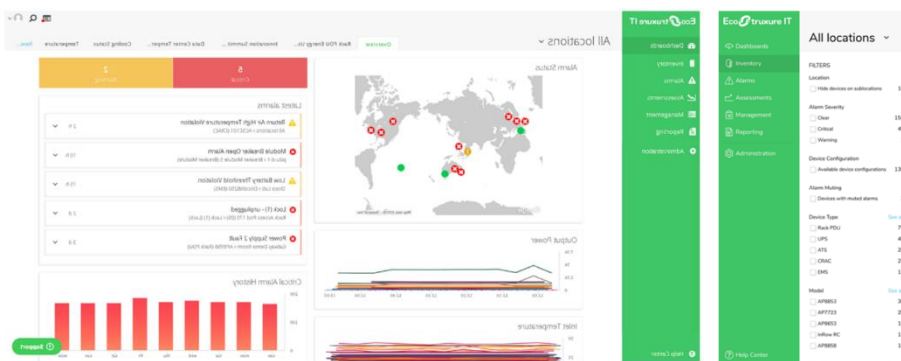

The NetBotz 750 offers an active monitoring solution designed to protect against environmental threats and unauthorized access risks that can cause downtime to IT infrastructure, in both Edge

Compute and Data Center environments. With its integrated suite of sensors, access control pods, and the newly introduced HD Camera Pod 165, the NetBotz 750 safeguards environments with surveillance and flexible alerting based on user-definable thresholds. Compute is quickly moving closer to where it is used at the Edge, increasing the risks of water damage, high temperature & humidity, fire or other conditions bringing down business-critical applications. Intentional or malicious access events not only threaten compute availability, but also leave enterprises vulnerable to costly compliance violations. The NetBotz 750 provides integrated sensing, surveillance, and badged rack-access control to help mitigate these risks through a wide array of compatible sensors, camera clip capture and storage, and configurable alarming

The Netbotz 750 system will monitor the following information inside the module:

- (1) Temperature point mounted on the front of each rack
- (1) Humidity level in the cold aisle
- Status of all the external doors
- Security cameras at each external door location
- Dry contact alarm status on the fire panel

5 Fire Suppression System

The fire protection system is designed to prevent, detect and extinguish possible fires inside the rooms. This will be an automatic system innocuous for people, goods and friendly environment. It will include the following equipment:

- Fire Control Panel
- Smoke Detection System (optional)
- Fire extinguishing system based on Novec 1230

5.1 Fire Control Panel



The fire panel controls the fire detection and extinguishing system. The panel can monitor two distinct areas, can trigger at least 2 levels of alarms, and incorporate a delay to evacuate the room before activating the extinguishing system. The system can also be activated by a manual switch attached to the panel.

This solution will implement a Honeywell Notifier RP1R Supra fire panel with following features:

- Compact and dual microprocessor central
- Easy configuration via micro switches
- Two conventional detection zones for detectors, and a third configurable for auto or manual trigger button
- Stop push button and extinction wait button
- Day / Night function with configurable delay (30 - 300 sec.) And inspection time (1 - 10 min.0
- Possible delays disabled from the keyboard
- Flow switch inputs, low pressure, monitoring door open
- Two extinction circuits, the extinction circuit 2 can be independent for pre-activation
- Countdown timer indicating the seconds left to extinction
- 40 LED display for quick identification the event
- Relays for: warning, alarm in the process of extinction, extinction canceled, extinction circuit failure, and fault relay
- Operating mode: automatic, manual and canceled
- Dry contact input for remote programmable actions as: reset the system, evacuation, mute or delay On / Off
- Removable terminal blocks in all connections
- PC state visualization software with optional remote connection
- Complies with European standards EN54-2/4 and EN12094 / 1:2003
- CE marked

(Additional control panels and features available upon request)

5.2 Smoke Detector

Model SD-851E photo-electronic detectors use state-of-the-art optical sensing chambers. The ability to plug these detectors into a variety of base options extends panel compatibility and application flexibility. These detectors are designed to provide open area protection and are only to be used with compatible control panels.

A bicolor LED on each detector lights red to provide a local visible alarm indication, and may also be set to flash green to indicate correct operation of the detector.

5.3 Extinguishing system

The automatic fire extinguishing system will be able to extinguish the fire quickly using clean extinguishing agents that don't damage the equipment to be protected. The gas release will be ordered by the fire panel at the second alarm level and once the timeframe expires. Gas can also be released manually in case the automatic system fails. Cylinders will be made of alloy steel Cr-Mo forged, seamless, with subsequent heat treatment of quenched and tempered. The system includes leakage control pursuant to regulation 842/2006/CE.

System is design with approval Transportable Pressure Equipment Directive. Hydraulic test pressure 250bar.

5.3.1 NOVEC 1230

NOVEC 1230 suppress fire is used in specific hazards or equipment located where an electrically nonconductive agent is required, where agent cleanup creates a problem, where extinguishing capability with low weight is a factor and where the hazard is normally occupied by personnel.

NOVEC 1230 is intended to protect the following installations:

- Petrochemical Installations
- Data Centers
- Gas Turbines
- Steam Turbine Generators
- Railway Traffic Controls
- Power Generation Plants
- Electrical Equipment
- Printing Facilities
- Electric Furnaces
- Food Packaging Facilities

Features:

- People safe at concentration levels required to suppress fire
- Zero ozone depletion potential
- Atmospheric lifetime of five days

- Colorless, with low odor with no particulate or oily residue allowing for minimal business disruption after a discharge
- Electrically non-conductive
- Space saving; quantity of NOVEC 1230 fluid needed to suppress fires typically required minimal cylinders, thus minimal space required.

Properties:

- Chemical name Dodecafluoro-2-methylpentan-3-one
- Chemical formula $\text{CF}_3\text{CF}_2\text{C}(\text{O})\text{CF}(\text{CF}_3)_2$
- Compliance with ISO 14520, UNE 23570 and NFPA 2001 FK-5-1-12
- Molecular weight 316.04
- Boiling point at 1.013 bar 49.20 C
- Liquid density at 200 C 1,616 g/ml
- Critical temperature 168.660 C
- Critical pressure 18.646bar
- Vapor pressure at 200 C 0.3260bar
- Relative electrical resistance at 1atm. 250 C (N2=1.0) 2.0
- Maximum filling density 1.48 kg/l
- Design concentration for heptane 5.9%
- Flooding factor for heptane at 200C 0.8723kg/m³
- Design concentration for surface fires class A 5.3%*
- Flooding factor for surface fires class A 0.7786kg/m³
- NOAEL 10%
- LOAEL >10%
- Ozone depletion potential 0
- Greenhouse effect potential 1

*According to ISO 14520

Approvals:

NOVEC 1230 fluid is approved by the EPA and NFPA for use in fire suppression systems.

Gas, pipe, pipe fittings, bottle fittings, chrome steel diffusers, stainless diaphragms, manual pulls, system abort button, and protected local labels will be included.

6 Cooling



The Uniflair WM is a completely self-contained cooling unit, meaning there is no need for a remote heat exchanger. These rapidly deployable units only require simple electrical wiring and mounting to the shelter. Available in a free cooling configuration, these units come equipped with motorized dampers to enable use of outside air to help cool the IT space.

Convenience

- **Self-Contained** - The unit is quickly and easily installed without the need for refrigerant lines or remote heat exchangers.
- Monoblock conditioning units can be installed on the outside wall of the air-conditioned room.

Economy

- **Direct Free Cooling** - The direct free-cooling units (WMF) are supplied with a motorized damper. During free-cooling the excess air is expelled from the room through the condenser section without using any extra over-pressure dampers.

Manageability

- **Building management system integration** - Units are designed to work with the most common BMS systems including BACnet and Modbus.

Serviceability

- **Easy service access** - Complete access to all the components allows servicing entirely from the outside, without having to enter the room which is normally protected by controlled access.
- The double external paneling is available in galvanized, painted sheet steel and gives separate access to the fan compartment and electric board compartments. This enables maintenance and regulation to be carried out without having to turn the unit off.

Overview

Model Name	Monoblock Wall Mounted Unit, External Installation with Upflow Air Discharge and Direct Free-Cooling
Model	WDF0501

General

Type	Air condensed
Net Total Cooling Power	15,0 kW
Net Sensible Cooling Power	15,0 kW

Maximum Evaporator Airflow	4200 m ³ /h
Refrigerant	R407C
N° of evaporator fans	2
N° of condenser fans	1
Compressor Type	Scroll
Compressor power consumption	3,78 kW

Input (Indoor Unit)

Nominal Input Voltage	400V/3+N
Input Frequency	50 Hz

Physical (Outdoor Unit)

Height	1800 mm
Width	1120 mm
Depth	650 mm

Conformance

Approvals	CE
Standard warranty	1 year (parts only) , 1 year on-site repair or replace with factory authorized Start-Up

7 GALAXY VS - Uninterruptible Power Supply (UPS)

Galaxy VS



Galaxy VS is a highly efficient, modular, easy-to-deploy 10 to 150 kW (400 V), three-phase uninterruptible power supply that delivers top performance for edge, small, and medium data centers, as well as critical infrastructure in commercial and industrial facilities.

Its compact design, high-density technology, N+1 redundancy, and fault-tolerant architecture maximize availability, operational efficiency, and critical load protection, while minimizing total cost of ownership.

Thanks to patented technologies, this UPS delivers up to 97% efficiency in normal operating mode and up to 99% in ECO conversion mode, equivalent to 66% higher energy savings.

Galaxy VS is EcoStruxure connected to give you peace of mind anytime, anywhere. Smart modular batteries integrated in the UPS cabinet optimize footprint and ensure critical loads have highly predictable runtimes. With its robust design and industry-leading performance, Galaxy VS is the ideal backbone for your critical infrastructure.

Availability

- **Parallel-capacity capable** - Increases total power capacity by using multiple uninterruptible power supplies simultaneously.
- **Compatible with Schneider Electric's lithium ion battery solution** - Reduces system footprint and weight, cooling and maintenance requirements, and total cost of ownership; offers double the life of VRLA batteries; and improves backup storage predictability and manageability.
- **Flexible DC bus** - Optimizes battery sizing and supports a wide range of energy storage technologies, including VRLA, Li-ion, and NiCd batteries.
- **Built-in backfeed protection** - Full built-in backfeed contactor ensures that no electricity is sent back to the grid.
- **Parallel-redundant capable** - Power the connected equipment with multiple uninterruptible power supplies to increase system redundancy
- **Embedded Network Management Card** - Allows you to remotely manage alert thresholds and monitor your UPS over EcoStruxure IT, Web, SNMP, or Modbus TCP and Modbus RTU

Serviceability

- **Multiple levels of service offers** - With the option of packages or individual service components, our services are structured to allow you to pick and choose what you would like Schneider Electric to do for you.
- **Front-access servicing** - Simplifies installation and UPS maintenance while minimizing space requirements.

- **Modular UPS design** - Provides design redundancy and fast serviceability with improved mean time to repair, via self-diagnosing, field-replaceable modules.
- **EcoStruxure IT Expert** - From your smartphone or computer, connect to our cloud-based, do-it-yourself monitoring system that collects, organizes, and distributes critical alerts and key information in real time, providing a unified view of even highly distributed physical infrastructure environments. Optimize your uptime and maintenance planning, and anticipate infrastructure issues before they occur with advanced analytics and performance benchmarking.

Total Cost of Ownership

- **Wide input voltage range** - Designed for harsh electrical environments to save battery life.
- **High efficiency in double conversion mode** - Consistently high power quality at high efficiency, even at low load levels. Any disturbances on the distribution waveform are regenerated via the zero transfer time AC to DC then DC to AC conversion process. The battery is only used as a back-up source.
- **ECONversion mode** - Operating mode that ensures ultra high efficiency while charging the batteries, conditioning the load power factor and ensuring a Class 1 output voltage regulation.
- **Compact UPS** - High-density technology and full front access make this UPS a footprint saver well suited for confined spaces.
- **Robust operation** - No power derating in kW up to 40 degrees C or 104 degrees F.
- **Input Power Factor Correction** - Minimizes installation costs by enabling the use of smaller generators and cabling..
- **Model:** GALAXY VS 50KVA
- **Rated power (kVA):** 50
- **Rated power (kW):** 50
- **UPS Redundancy:** N
- **SKU:** GVSUPS50KB4HS

Galaxy VS		400 V
Topology	On-line double conversion	
Nominal power (kW)	10-150 kW (parallel up to 450 kW) [3 UPSs in parallel]	
Key features		
Scalability option	50-150 Kw	
N+1 redundancy option	20-50 kW N+1	
Modular elements	Power modules, static switch module, smart battery modules, intelligence module	

Display	Color touch screen, 4.3 inches, status LED, mimic on display
Communication	Network management card included with ethernet (SNMP) and Modbus. 8 dry contacts (4 inputs, 4 outputs)
Maintenance bypass	Internal maintenance bypass. Optional maintenance bypass panel
Parallel capability	Simplified 1+1 parallel (for redundancy); Up to 3 UPSs for capacity or 3+1 UPSs for redundancy
Efficiency	
Double conversion mode	Up to 97%
ECO mode	Up to 99%
ECONversion mode	Up to 99%
Input	
Nominal input voltage	380 / 400 / 415 V
Input voltage range (phase to phase)	+/-15%
Single mains/dual mains	Single mains as standard. Easily converted to dual mains
Input frequency	40-70 Hz
Input power factor	IEC power factor: >0.99 @ load >25%, >0.95 @ load > 15%
Maximum short-circuit rating	65 kA
Back feed protection	Included
Output	
Nominal output voltages	380 / 400 / 415 V
Load power factor	PF=1 (0.7 leading to 0.7 lagging without derating)
Voltage regulation	+/- 1%
Frequency	50 / 60 Hz +/-0.1% free running
Overload	1 min @ 150%; 10 min @ 125%
Output THDU on linear load	<1%
Battery type	VRLA, Li-ion
Nominal battery voltage, UPS for external batteries	480 – 576 V (at ratings 50 kW, 100 kW, 150 kW); 60 kW: 432 – 576; 384 – 576 V (at other ratings, including 60kW and 120kW)
Nominal battery voltage, UPS with internal batteries	480 V DC

Charging power	Charging power in % of output power at 0-40% load: 80% Charging power in % of output power at 100% load: 20%
Environment	
Acoustic noise, UPS for external batteries	57 dB (70% load) / 65 dB (100% load)
Acoustic noise, UPS with internal batteries	54-65 dB, depending on load percentage and model
Dust protection	Air filter included. Conformal coated boards
Seismic	With optional kit. OSHPD tested

8 Racks - NetShelter SX/SV



APC NetShelter rack enclosure maximizes flexibility with a progressive, non-proprietary feature-set as well as an extensive line of scalable accessory products to address current needs and adapt to future technology trends. APC NetShelter® rack systems provide a progressive feature-set available in a vendor-neutral rack environment while allowing the user the flexibility to quickly adapt to emerging trends. NetShelter racks and enclosures support can adapt of any type of applications.

These enclosures are designed to meet current IT market trends and applications ranging from high density computing and networking to broadcast and audio-video. With a strong focus on cooling, power distribution, cable management and environmental monitoring, the NetShelter SX rack enclosure provides a reliable rack-mounting environment for mission-critical equipment.

The NetShelter SV is the IT enclosure you have become familiar with from Schneider Electric but now with basic functionality and features provided as a cost-effective solution. The NetShelter SV maintains a strong focus on cooling, power distribution, and cable management to provide a reliable rack-mounting environment for mission-critical equipment but with optional features such as side panels or even an unassembled option that reduces the cost of the base enclosure.

Convenience

- **Cable access openings with pre-installed brushes** - Large cable access slots in the roof provides access for overhead cable egress. The bottom design allows for unobstructed cable access through a raised floor. Roof includes openings with brush strips pre-installed in locations biased towards the front of the enclosure to allow for data cable pass through and provisions for air containment.
- **Half-height side panels and option with brush strips for pass-through** - Half-height quick release side panels reduce size and weight for easy handling and access to equipment. Side panels are lockable utilizing a single key with the doors. Now available are side panel options integrated with pass-through holes and brush strips for routing cabling to adjacent racks in a row while still maintaining proper airflow.
- **Perforated front door with curved profile** - Perforated front and rear doors provide ample ventilation for servers and networking equipment. Front door perforated area is optimized with a curved profile to provide greater surface area and allowance of more perforation coverage and higher perforation rating.
- **Quick release doors** - Front door can be moved to the opposite side or interchanged with rear doors. Doors are easily removed with simple lift-off design.

Agility

- **Adjustable mounting rails with captive hardware and rapid alignment** - The vertical mounting rails can be adjusted in 1/4 in (6.4 mm) increments covering virtually any mounting requirement for IT equipment. Easy alignment feature integrated into the enclosure mounting rail and side brace for quick alignment verification without the use of

tools to verify alignment. U positions are numbered front and back for rapid installation of equipment.

- **Integrated joining hardware with multiple width enclosure alignment** - Enclosures include pre-installed joining hardware to join enclosures in a row and provide additional stability to the enclosure. The pre-installed joining hardware includes holes for joining to an adjacent enclosure at 600mm centers or 24in centers depending upon the floor layout.
- **Low-profile castors and adjustable leveling feet from underneath or above** - Enclosures are shipped standard with both leveling feet and castors. Leveling feet can be quickly adjusted using a screwdriver or drill, eliminating the need to reach underneath with a wrench.
- **Pre-installed full-enclosure height rear accessory channels** - Integrated and adjustable rear accessory channel provides zero U mounting locations for tool less accessories. Each channel has two mounting bays to support a combination of up to four accessories such as PDUs and vertical cable organizers. 1070mm (42in), 825mm (32 in), and deep enclosures and networking enclosures include two channels. 1200mm (48in) deep enclosures include four channels. Channels are pre-installed at the factory in the rear of the enclosure but can be moved to other locations of the enclosure along the side brace to resituate cable management where it is needed most.
- **Split rear doors** - Split rear doors improve access and serviceability to rear of rack mounted equipment. The split rear doors help to maximize floor space. Only 11 inches (279 mm) of clearance is required behind the enclosures to allow for door swing.

Safety

- **Designed for enhanced structural stability** - A proven frame design, heavy-gauge mounting rails.

- **Model:** [[Value not found]]
- **Description:** [[Value not found]]
- **Number of racks:** 7

Rack Model	AR2480	AR2580	AR3100	AR3150	AR3300	AR3350
Overview						
Includes	Baying hardware, Key(s) , Keyed-alike doors and side panels , Leveling feet , Mounting Hardware , Pre-installed casters , Side Panels					
Physical						
Net Weight	130.5 kg	139.5 kg	125.09 kg	155.96 kg	134.09 kg	161.37 kg
Maximum Height	2057.0 mm		1991.0 mm			
Maximum Width	800.0 mm		600.0 mm	750.0 mm	600.0 mm	750.0 mm
Maximum Depth	1060 mm	1200 mm	1070.0 mm		1200.0 mm	
Rack Height	42 U	42 U	42 U	42 U	42 U	42 U
Color	Black					

Vertical Posts	18 gauge	16 gauge			
Front Door	16 gauge				
Rear Door	16 gauge	18 gauge	16 gauge	18 gauge	16 gauge
Roof	19 gauge	18 gauge			
EIA Mounting Rails	14 gauge				
Side Panels	18 gauge				
Conformance					
Approvals	UL 2416, UL 60950-1, EIA-310E				
Standard warranty	5-year repair or replace				
Offer Sustainability					
RoHS	Compliant				
REACH	REACH: Contains No SVHCs				
Other Environmental Compliance	China RoHS				
Sustainable Offer Status	Green Premium product				

Rack Model	AR2487	AR2587	AR3107	AR3157	AR3307	AR3357
Overview						
Includes	Baying hardware, Key(s) , Keyed-alike doors and side panels , Leveling feet , Mounting Hardware , Pre-installed casters , Side Panels					
Physical						
Net Weight	143.8 kg	152.8 kg	138.23 kg	169.09 kg	149.56 kg	185.45 kg
Maximum Height	2324 mm	2324 mm	2258.0 mm			
Maximum Width	800.0 mm		600.0 mm	750.0 mm	600.0 mm	750.0 mm
Maximum Depth	1060 mm	1200 mm	1070.0 mm		1200.0 mm	
Rack Height	48 U	48 U	48 U	48 U	48 U	48 U
Color	Black					
Vertical Posts	18 gauge		16 gauge			
Front Door	16 gauge					
Rear Door	16 gauge		18 gauge	16 gauge	18 gauge	16 gauge
Roof	19 gauge	18 gauge				
EIA Mounting Rails	14 gauge					

Side Panels	18 gauge
Conformance	
Approvals	UL 2416, UL 60950-1, EIA-310E
Standard warranty	5-year repair or replace
Offer Sustainability	
RoHS	Compliant
REACH	REACH: Contains No SVHCs
Other Environmental Compliance	China RoHS
Sustainable Offer Status	Green Premium product

8.1 Rack Power Distribution

APC Metered Rack Power Distribution Units (PDUs) provide active metering to enable energy optimization and circuit protection. User-defined alarm thresholds mitigate risk with real-time local and remote alerts to warn of potential circuit overloads. Metered Rack PDUs provide power utilization data to allow Data Center Managers to make informed decisions on load balancing and right sizing IT environments to lower total cost of ownership. Users can access and configure Metered Rack PDUs through secure Web, SNMP, or Telnet Interfaces which are complimented by APC Centralized Management platforms using StruxureWare Data Center Expert, Operations, Capacity, and Energy Efficiency.

AP8000 series Metered Rack PDUs include real power monitoring, a temperature/humidity sensor port, locking IEC receptacles, and ultra-low profile circuit breakers.

Features:

- Load indicator LED. Indicates overload and warning conditions based on the user-defined alarm thresholds. Alerts users of potential overloaded circuits.
- Integrates with StruxureWare Data Center Expert. An IT-ready, scalable access monitoring system that collects, organizes, and distributes critical alerts, surveillance video and key information, providing a unified view of complex physical infrastructure environments from anywhere on the network
- Flash Upgradeable. Quickly and easily upgrade firmware via network download for future product enhancements. Eliminates the need to replace products already installed in the field when new features are released. (Note: Networked units only)
- Alarm Thresholds. Define alarm thresholds in order to avoid overloaded circuits. Network and visual alarms inform the user of possible problems. (Note: Only available on units with the current monitoring capabilities. Please see SKU specifications for availability)
- Local Current Monitoring Display. The aggregate current draw per rack PDU is displayed on the unit via a digital display. The local digital display helps installers avoid overloaded circuits by providing a visible warning when the current draw is close to the maximum amperage draw of the strip. (Available on designated SKUs only)

- **Remote Management Capabilities.** Full-featured network management interfaces that provide standards-based management via Web, SNMP, and Telnet. Allows users to access, configure, and manage units from remote locations to save valuable time. Associated with this feature is the ability to quickly and easily upgrade the firmware via network download to installed units for future product enhancements.



Overview

Model Name	AP8853
Includes	Installation guide, Rack Mounting brackets, Safety guide, Serial configuration cable

Output

Nominal Output Voltage	230V
Maximum Total Current Draw per Phase	32 A
Output Connections	(36) IEC 320 C13 (Battery Backup), (6) IEC 320 C19 (Battery Backup)
Always on Outlets	0
Overload Protection	Yes

Input

Nominal Input Voltage	200V, 208V, 230V
Input Frequency	50/60 Hz
Input Connections	IEC 309 32A 2P+E
Cord Length	3 meters
Number of Power Cords	1
Acceptable Input Voltage	220-240 VAC
Maximum Line Current per phase	32 A

Maximum Input Current per phase	32 A
Load Capacity	0 VA

Physical

Net Weight	6.93 kg
Maximum Height	1791.0 mm
Maximum Width	56.0 mm
Maximum Depth	44.0 mm
Shipping Weight	8.56 kg
Shipping Height	2000.0 mm
Shipping Width	162.0 mm
Shipping Depth	107.0 mm
Color	Black

Environmental

Operating Environment	-5 - 45 °C
Operating Relative Humidity	5 - 95 %
Operating Elevation	0-3000 meters
Storage Temperature	-25 - 65 °C
Storage Relative Humidity	5 - 95 %
Storage Elevation	0-15000 meters

Conformance

Approvals	IEC 60950, VDE
Standard warranty	2 years repair or replace

Sustainable Offer Status

RoHS	Compliant
REACH	REACH: Contains No SVHCs
Battery Directive	Compliant
Battery Notes	Battery Notes

9 Exclusions

The following list gives the limit of our scope of supply. All works listed hereafter are excluded from this proposal.

General:

- Any item not specifically listed in the proposal
- Freight to the final site
- Unloading of the module into its final position
- Project management services

Civil works:

- Any outdoor and indoor civil works (e.g. trenches, preparation of foundations, concrete slabs, fireproof walls, doors, holes, stairs...)
- Any opening or drilling in the building existing walls and roof
- Any scaffolding, builders work or allied tradesman work
- Any ceiling or overhead plenum
- Installation of condensers on external slab
- Attachment of piping between condensers and module
- Any steps or ramps required for doorways

Data cabling:

- Any IT cabling and fiber optics installation

Electrical cabling:

- Any electrical installation work outside the prefabricated building solution
- Any digging, trenches and soil preparation for fuel tank and piping network installation
- The supply and installation of the incoming LV electrical supply from the gensets
- The supply and installation of the incoming LV electrical supply from the normal source

Electrical equipment:

- Emergency gensets including fuel tanks